

ROUTE 145, WINTHROP ROAD
CHESTER, CONNECTICUT 06412-0684
TELEPHONE: (860) 526-9504
FAX: (860) 526-4078

Notice! This WPPS690 strobe power supply, like all Whelen components, can be installed in many different types of vehicles. The guidelines for the installation of this product are written so that no matter what vehicle is being used, the installation and operation of the WPPS690 will be simple and straight forward.

Selecting a Mounting Location:

The most common choice for a mounting area would be a trunk or similar compartment. However, due to the wide variety of vehicles onto which the WPPS690 could be installed, this is not always possible. The following guidelines will help the installer select an acceptable alternative:

- A) The WPPS690 should be mounted on a metal surface to aid heat dissipation. Be sure that this surface is not one that either generates or is exposed to excessive heat during normal operation of the vehicle.
- B) Do not select a location where the WPPS690 will be exposed to potential damage from any unsecured or loose equipment in the vehicle.
- C) When routing the WPPS690's wires, it is important to choose a path that will keep these wires away from excessive heat and from any vehicle equipment that could compromise the integrity of the wires (ex. trunk lids, door jams, etc.).
- D) When the best mounting location has been determined, securely fasten the WPPS690 to it's mounting surface using the supplied hardware.

WARNING: The Strobe Light Power Supply is a high voltage device. Do not touch or remove tube assembly in strobe light head assemblies while in operation. Wait 10 minutes after disconnecting the unit from its power source before starting work or troubleshooting on power supply or system.

CAUTION: As it will be necessary to drill holes into the mounting surface, the installer **MUST** be sure that no vehicle components or other vital parts could be damaged by the drilling process. Check both sides of the mounting surface before drilling begins!

1. Position the WPPS690 in its proposed mounting location to ensure that it fits properly. With the WPPS690 in place, insert an awl or other suitable tool into the mounting screw area of the power supply and scribe the areas that are to be drilled.

2. Remove the WPPS690 from its mounting area and, using a drill bit sized for a #10 sheet metal screw, drill a hole in each of the areas scribed in the previous step.
3. Return the WPPS690 to its mounting location and using the supplied #10 sheet metal screws, mount the WPPS690 onto its mounting surface.

Wiring your WPPS690:

1. Locate the 8 position **Input Harness Plug** and connect as indicated in Fig. 1. Extend the BLACK and RED wires from the **Input Harness Plug** towards the battery.

WARNING: All customer supplied wires, that connect to the positive (+) terminal of the battery, must be sized to supply at least 125% of the maximum operating current, and fused "at the battery" to carry the load!

2. Connect the RED wire to a fuse block (customer supplied) and then to the POSITIVE terminal on the battery.

NOTE! Although a 15 amp fuse (customer supplied) is required to be used in the fuse block, do not install the fuse until *all* of the wire connections are completed.

3. Connect the BLACK wire to the factory chassis ground adjacent to the battery.
4. Refer to Fig. 1 for detailed wiring information.

Correct Use Of The Water-proof Butt Splice:

Water-proof butt splices have been included. The proper use of these splices will help prevent premature corrosion of your strobe connections. However, the effectiveness of these splices is directly related to their proper installation. Splice the two wires together as would be done with a regular butt splice. After the wires have been crimped, pass a heat gun over the splice until the outer tubing shrinks around the wires, thus water-proofing the connection. Be sure to keep the heat gun moving over the splice to prevent burning the connector.

Fig. 1

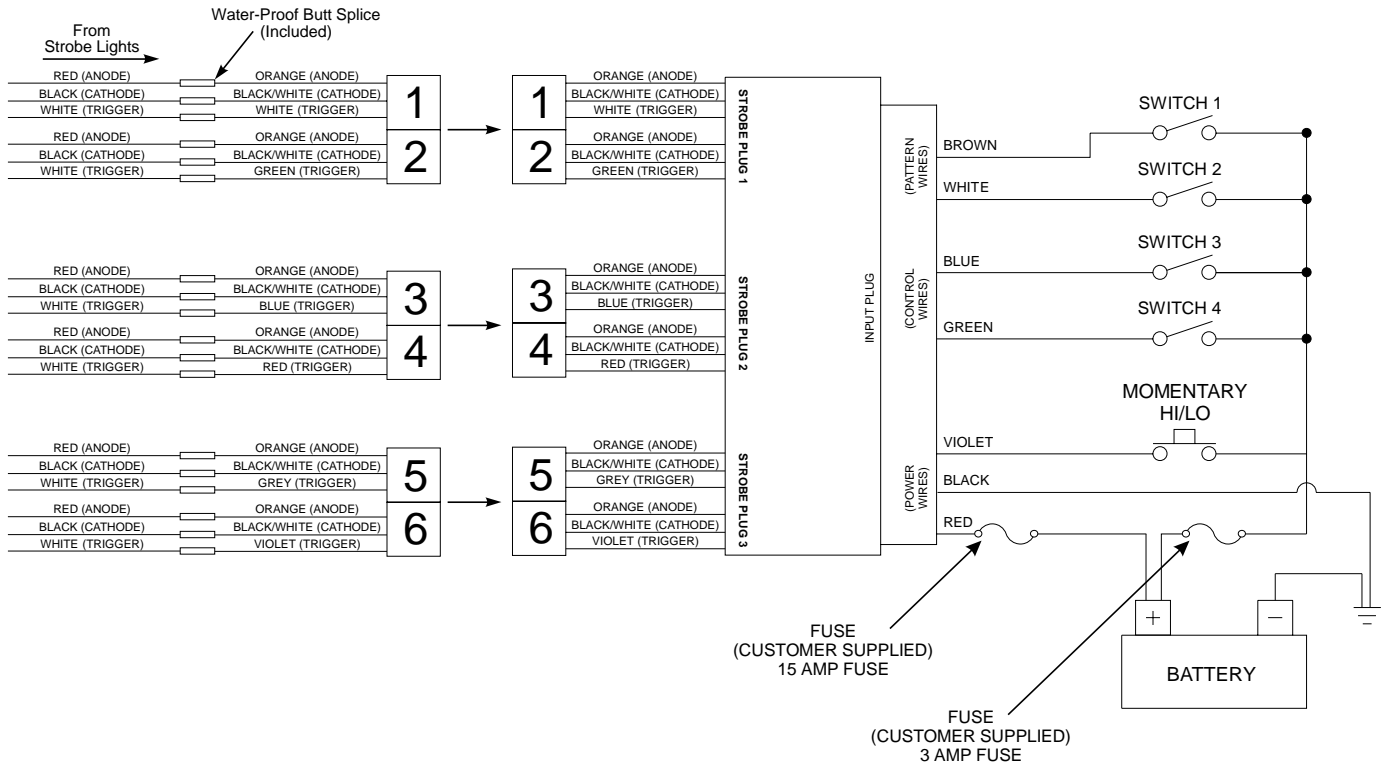

Switch Operation Table

Pattern Control (Switches 1 & 2)

Outlet Control (Switches 3 & 4)

Switches 1&2 Disabled	Comet Flash Pattern	Switches 3 & 4 Disabled	No Strobe Plugs Active
Switch 1 Enabled	Double Flash Pattern	Switch 3 Enabled	Strobe Plugs 1 & 3 Active
Switch 2 Enabled	Single Flash Pattern	Switch 4 Enabled	Strobe Plug 2 Active
Switches 1&2 Enabled	Action Flash Pattern	Switches 3&4 Enabled	All Strobe Plugs Active

WPPS690 SPECIFICATIONS:

INPUT VOLTAGE	-	12.8 VDC ± 20%
INPUT CURRENT (OFF)	-	0 AMPS
INPUT CURRENT (30 WATTS)	-	3 AMPS (TYP)
INPUT CURRENT (60 WATTS)	-	6 AMPS (TYP)
INPUT CURRENT (90 WATTS)	-	9 AMPS (TYP)
FLASHRATE COMET	-	75 FPM (PER LAMP) @ 85 ms
FLASHRATE DOUBLE FLASH	-	110 FPM (PER LAMP) @ 100ms
FLASHRATE SINGLE FLASH	-	240 FPM (PER LAMP)
FLASHRATE ACTION	-	3 CYCLES (COMET) - 4 CYCLES (SF)
INPUT CONTROL VOLTAGE	-	13.5 VDC ±20%
INPUT CONTROL CURRENT	-	50 MA (TYP)
ENERGY 60 WATT MODE	-	26.5 JOULES (TOTAL) 11.5 / 5 / 5 / 5 JOULES
ENERGY 90 WATT MODE	-	36 JOULES (TOTAL) 15 / 7 / 7 / 7 JOULES
ENERGY LO POWER MODE	-	10 JOULES (TOTAL) 2.5 / 2.5 / 2.5 / 2.5 JOULES

Lo Power Operation Note

Applying 12 VDC to the VIOLET wire activates Lo Power operation mode. The power supply is now effectively "latched" into this mode. To restore normal, High Power operation, it is necessary to turn the power supply off, and then on again. When the power supply restarts, it will be in its normal, High Power operating mode.