

ROUTE 145, WINTHROP ROAD  
CHESTER, CONNECTICUT 06412-0684  
TELEPHONE: (860) 526-9504  
FAX: (860) 526-4078

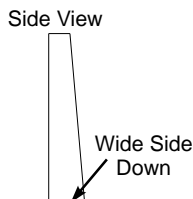
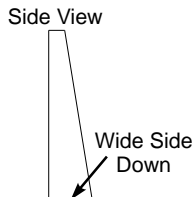
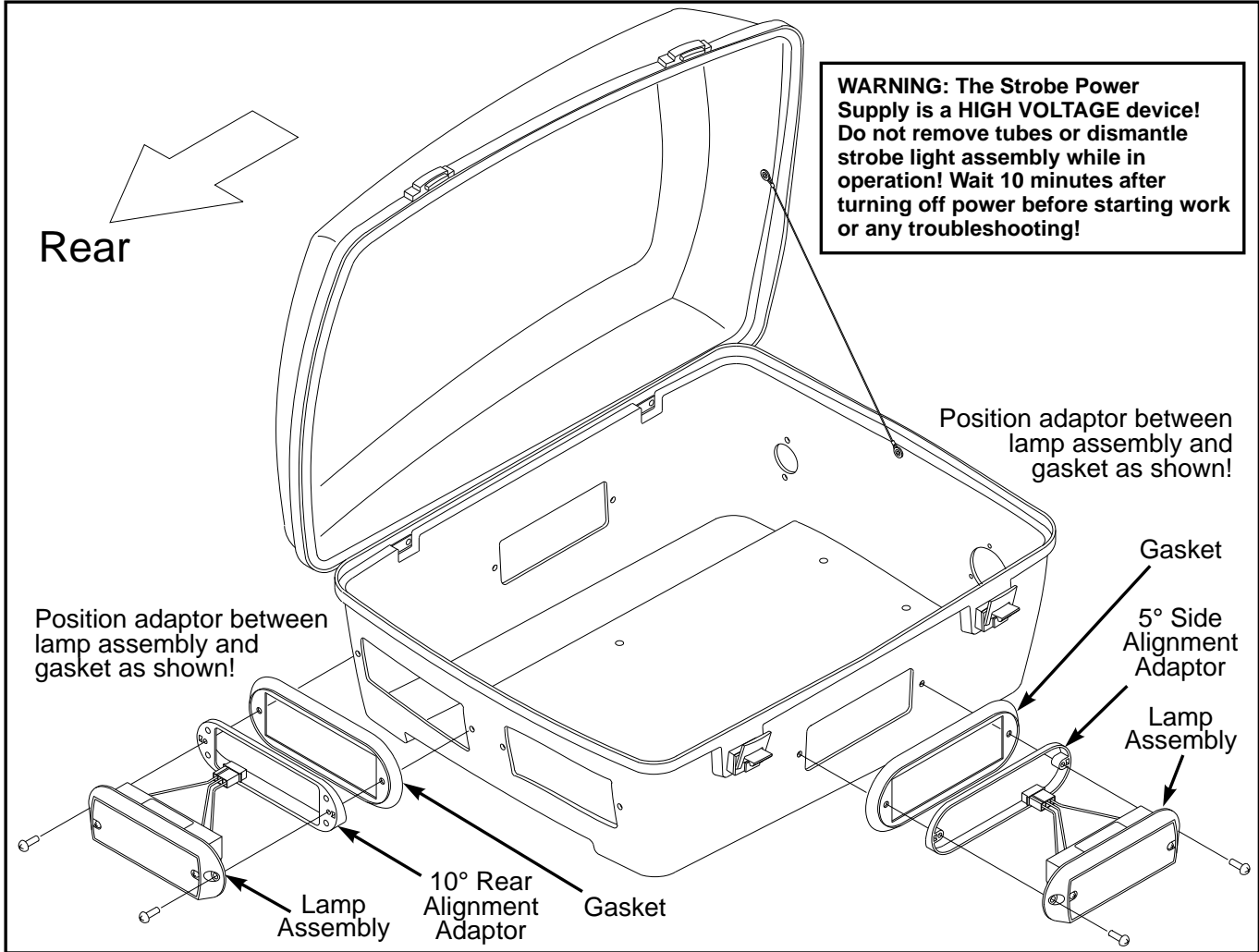

**Installing the adaptor...**

1. Remove the two screws that secure the lamp assembly to the box and unplug the lamp assembly from the power supply.
2. Position the alignment adaptor between the lamp assembly and the gasket, making sure that the wider side of the adaptor is down.  
**NOTE: Be sure to use the 10 degree adaptor on the rear lamps and the 5 degree adaptor on the side lamps.**
3. Reconnect the lamp assembly to the power supply. Using the new hardware included with this kit, remount the lamp assembly.