

WHELEN[®]

ENGINEERING COMPANY INC.

Route 145, Winthrop Road,

Chester, Connecticut 06412

Phone: (860) 526-9504

Fax: (860) 526-4078

Internet: www.whelen.com

Sales e-mail: autosale@whelen.com

Canadian Sales e-mail: autocan@whelen.com

Customer Service e-mail: custserv@whelen.com

Installation Guide: Model ISP4HS Strobe/Halogen Power Supply

Safety First

This document provides all the necessary information to allow your Whelen product to be properly and safely installed. Before beginning the installation and/or operation of your new product, the installation technician and operator must read this manual completely. Important information is contained herein that could prevent serious injury or damage.

- **Proper installation of this product requires the installer to have a good understanding of automotive electronics, systems and procedures.**
- **If mounting this product requires drilling holes, the installer MUST be sure that no vehicle components or other vital parts could be damaged by the drilling process. Check both sides of the mounting surface before drilling begins. Also de-burr any holes and remove any metal shards or remnants. Install grommets into all wire passage holes.**
- **If this manual states that this product may be mounted with suction cups, magnets, tape or Velcro™, clean the mounting surface with a 50/50 mix of isopropyl alcohol and water and dry thoroughly.**
- **Do not install this product or route any wires in the deployment area of your air bag. Equipment mounted or located in the air bag deployment area will damage or reduce the effectiveness of the air bag, or become a projectile that could cause serious personal injury or death. Refer to your vehicle owners manual for the air bag deployment area. The User/Installer assumes full responsibility to determine proper mounting location, based on providing ultimate safety to all passengers inside the vehicle.**
- **For this product to operate at optimum efficiency, a good electrical connection to chassis ground must be made. The recommended procedure requires the product ground wire to be connected directly to the NEGATIVE (-) battery post.**
- **If this product uses a remote device to activate or control this product, make sure that this control is located in an area that allows both the vehicle and the control to be operated safely in any driving condition.**
- **Do not attempt to activate or control this device in a hazardous driving situation.**
- **It is recommended that these instructions be stored in a safe place and referred to when performing maintenance and/or reinstallation of this product.**
- **FAILURE TO FOLLOW THESE SAFETY PRECAUTIONS AND INSTRUCTIONS COULD RESULT IN DAMAGE TO THE PRODUCT OR VEHICLE AND/OR SERIOUS INJURY TO YOU AND YOUR PASSENGERS!**

For warranty information regarding this product, visit www.whelen.com/warranty

The ISP4HS™ is a versatile strobe power supply serving as the fundamental building block for many Whelen emergency warning systems. The ISP4HS™ is used in the state-of-the-art Fast Trax™ lighting system, as well as the industry standard DOT systems pioneered by Whelen. In addition, the ISP4HS™ serves equally well as a stand alone synchronized strobe power supply and halogen flasher known as the Whelen SSNF systems.

Programming for the various applications is selectable by a 4 position dip switch. 5 low current control lines allow flexible operator control and the system may be wired as simple or intricately as the users needs dictate.

When used in a stand-alone or DOT application, both the strobe and halogen outlets have Hi / Low intensity control. This may be wired for either latched or level control and the power supply will automatically sense which wiring has been selected and automatically adjust it's internal circuitry.

Another feature is the optional Diagnostix™ display. This allows the operator to confirm proper operation of the system in "real time" and diagnose system malfunctions. When used in a Fast Trax or standard DOT system, please refer to the system wiring instructions for the default wiring of the ISP4HS™, applicable to your system.

WARNING: *The Strobe Light Power Supply is a high voltage device. Do not touch or remove tube assembly in strobe light head assemblies while in operation. Wait 10 minutes after disconnecting the unit from its power source before starting work or troubleshooting on power supply or system.*

CAUTION: *As it will be necessary to drill holes into the mounting surface, the installer MUST be sure that no vehicle components or other vital parts could be damaged by the drilling process. Check both sides of the mounting surface before drilling begins!*

WARNING: **All customer supplied wires that connect to the positive terminal of the battery must be sized to supply at least 125% of the maximum operating current and FUSED at the battery to carry that load. DO NOT USE CIRCUIT BREAKERS WITH THIS PRODUCT! (See wire chart, this page)**

Selecting a Mounting Location:

The most common choice for a mounting area would be a trunk or similar compartment. However, due to the wide variety of vehicles onto which the unit could be installed, this is not always possible. The following guidelines will help the installer select an acceptable alternative.

- **The power supply should be mounted on a metal surface to aid heat dissipation. Be sure that this surface is not one that either generates or is exposed to excessive heat during normal operation of the vehicle.**
- **Do not select a location where the unit will be exposed to potential damage from any unsecured or loose equipment in the vehicle.**
- **Do not allow the unit to be exposed to water.**
- **When routing the power supplies wires, it is important to choose a path that will keep these wires away from excessive heat and from any vehicle equipment that could damage the wires (trunk lids, door jams, etc.).**

Mounting your ISP4HS:

1. Position the ISP4HS in its proposed mounting location to ensure that it fits properly. With the unit in place, insert an awl or other suitable tool into the mounting holes of the power supply and scribe the areas to be drilled.
2. Remove the unit from its mounting area and, using a drill bit sized for a #10 sheet metal screw, drill a hole in each of the areas scribed in the previous step.
3. Return the power supply to its mounting location and using the supplied screws, mount the unit.

Wiring your ISP4HS:

1. Locate the 10 position *Input Connector* included with your ISP4HS and plug it into the port indicated on page 3. Extend the 2 BLACK wires, the RED wire and the WHITE wire from the *Input Connector* towards the battery.
2. Connect the RED wire to a fuse block (customer supplied) and then to the POSITIVE terminal on the battery.
3. Connect the WHITE wire to a fuse block (customer supplied) and then to the POSITIVE terminal on the battery.

NOTE: *Although a 15 amp fuse (customer supplied) is required to be used in the fuse block, do not install the fuse until all wire connections are completed.*

4. Connect the BLACK wires to the factory chassis ground adjacent to the battery.
5. Refer to diagram on page 3 for wiring information for the remaining *Switch Control Wires* and *Pattern Control Wires*.

RECOMENDED SIZE / CUSTOMER SUPPLIED WIRES

POWER AND GROUND	CONTROL LINES
18AWG 5 FT. MAX	22 AWG 5 FT. MAX
16 AWG 8 FT. MAX	20 AWG 16 FT. MAX
14 AWG 13 FT. MAX	18 AWG 26 FT. MAX
12 AWG 21 FT. MAX	16 AWG 41 FT. MAX
10 AWG 33 FT. MAX	

IF THE LED IS...	THEN...
OFF	Either the outlet in question is not enabled, or the power supply is not turned on.
ON continuously	The outlet, strobe cable and strobe light in question are functioning properly.
FLASHING rapidly	Either the outlet, strobe cable and / or strobe light in question are malfunctioning. In this condition, further investigation of components is strongly recommended
ON continuously with a single flash every few seconds	The ISP4HS is operating in Lo power mode.

Hi/Lo Power:



The type of switch used depends on how the operator wishes the Hi/Lo feature to function.

Latching Mode: By applying voltage to the Violet wire for less than 1 second the power supply is “latched” into low power operation. The unit must be turned off and back on to restore normal, Hi power operation. A momentary switch is desired for this style.

Level Mode: Applying voltage to the Violet wire for more than 1 second holds the power supply in low power mode until that voltage is removed. A toggle switch is desired for this style.

Diagnostix™ (Optional)

The optional Diagnostix™ display allows the operator to confirm proper operation of the 8 outlets on the ISP4HS by monitoring the Control Lines used to activate specific outlets, based on dip switch settings.

- Row 1 (top) CTRL 1 (Strobe)
- Row 2 CTRL 3 (Halogen)
- Row 3 CTRL 4 (Halogen)
- Row 4 (bottom) CTRL 2 (Strobe)

The LED’s appearance indicates the condition of its corresponding outlet, as shown in the table to left.

Dip Switch Functions

- Dip Switch #1 Strobe Pattern Control
- Dip Switch #2 Strobe Pattern Control
- Dip Switch #3 Sequence Control
- Dip Switch #4 Mode Control

Pattern Controls / Dip Switches 1 & 2

Switch 1	Switch 2	Flash Pattern
OFF	OFF	Comet Flash (Default)
OFF	ON	Double Flash
ON	OFF	Triple Flash
ON	ON	Action Flash

Sequence Control / Dip Switch 3

Switch 3	Model
OFF	Simultaneous (Default)
ON	Alternating

Mode Control / Dip Switch 4

Switch 4	Model
OFF	ISP4HS (Default)
ON	Fast Trax

Dip Switch Settings				Control Lines	Color	Outlets	Function
1	2	3	4				
OFF	OFF	OFF	OFF	1	BLUE	1 & 3	Simultaneous Strobe, Comet Flash
				2	GREEN	5 & 7	Simultaneous Strobe, Comet Flash
				3	YELLOW	2 & 4	Simultaneous Halogen, Single Flash
				4	GREY	6 & 8	Simultaneous Halogen, Single Flash
				5	VIOLET		Hi/Low Power
OFF	OFF	ON	OFF	1	BLUE	1 & 5	Alternating Strobe, Comet Flash
				2	GREEN	3 & 7	Alternating Strobe, Comet Flash
				3	YELLOW	2 & 6	Alternating Halogen, Single Flash
				4	GREY	4 & 8	Alternating Halogen, Single Flash
				5	VIOLET		Hi/Low Power
OFF	OFF	OFF	ON	1	BLUE	1 & 3	Simultaneous Strobe, Comet Flash
				2	GREEN	5 & 7	Simultaneous Strobe, Comet Flash
				3	YELLOW	2 & 4	Simultaneous Halogen, Double Flash
				4	GREY	6 & 8	Simultaneous Halogen, Double Flash
				5	VIOLET	6 & 8	Steady Burn / Take Down
OFF	OFF	ON	ON	1	BLUE	1 & 5	Alternating Strobe, Comet Flash
				2	GREEN	3 & 7	Alternating Strobe, Comet Flash
				3	YELLOW	2 & 6	Alternating Halogen, Double Flash
				4	GREY	4 & 8	Alternating Halogen, Double Flash
				5	VIOLET	4 & 8	Steady Burn / Take Down

Wiring Diagram

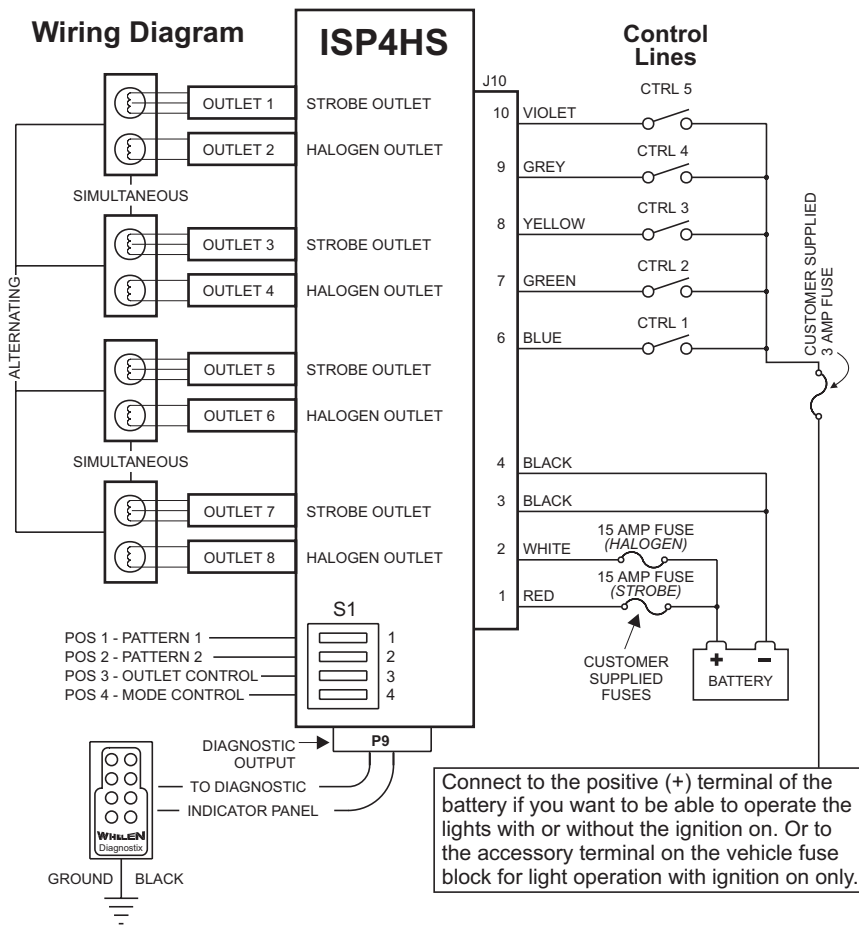

Connect to the positive (+) terminal of the battery if you want to be able to operate the lights with or without the ignition on. Or to the accessory terminal on the vehicle fuse block for light operation with ignition on only.

Strobe Specifications

- INPUT VOLTAGE _____ 12.8 VDC \pm 20%
- INPUT CURRENT
 - @ 45 WATTS _____ 4.5 AMPS
 - @ 90 WATTS _____ 9 AMPS
- INPUT POWER _____ 60/120 WATTS
- OUTPUT POWER _____ 45/90 WATTS
- FLASH PATTERNS
 - COMET FLASH (140FPM)
 - TRIPLE FLASH (140FPM)
 - DOUBLE FLASH (170FPM)
 - ACTION FLASH (140-170FPM)
 - 2 COMET, 2 DOUBLE
- ENERGY (MAX.) _____ 18 JOULES PER BURST
- V (OUTLET ENABLE) _____ 3.5 VDC (MIN)
- I (OUTLET ENABLE) _____ 20mA (TYP) @ 12.8 VDC
- V (HI/LO) _____ 3.5 VDC (MIN)
- I (HI/LO) _____ 20mA (TYP) @ 12.8 VDC

Halogen Specifications

- INPUT VOLTAGE _____ 12.8 VDC \pm 20%
- OUTPUT POWER _____ 35W MAX PER OUTLET

