

WHELEN®

ENGINEERING COMPANY INC.

Installation Guide For VPPS2C Remote Strobe Power Supply

ROUTE 145, WINTHROP ROAD
CHESTER, CONNECTICUT 06412-0684
TELEPHONE: (860) 526-9504
FAX: (860) 526-4078

WARNING... THE STROBE LIGHT POWER SUPPLY IS A HIGH VOLTAGE DEVICE. DO NOT REMOVE STROBE TUBES OR DISMANTLE STROBE LIGHT HEAD ASSEMBLIES IN SYSTEM WHILE IN OPERATION.

WAIT 10 MINUTES AFTER TURNING OFF POWER BEFORE STARTING WORK OR ANY TROUBLE SHOOTING.

IMPORTANT NOTE: STROBE LIGHT POWER SUPPLY IS NOT FIELD SERVICEABLE, RETURN TO MANUFACTURER FOR SERVICING. DO NOT TAMPER WITH UNIT!!!

INSTALL STROBE POWER SUPPLY WITH THE CONNECTIONS LOCATED IN SUCH A WAY THAT THEY ARE EASILY ACCESSIBLE.

WARNING: ALL CUSTOMER SUPPLIED WIRES, THAT CONNECT TO THE POSITIVE (+) TERMINAL OF THE BATTERY, MUST BE SIZED TO SUPPLY AT LEAST 125% OF THE MAXIMUM OPERATING CURRENT, AND FUSED AT THE BATTERY TO CARRY THAT LOAD.

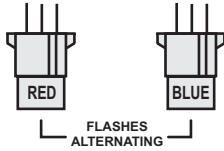

NOTE: ONLY THE ITEMS IN THIS BOX ARE INCLUDED WITH YOUR POWER SUPPLY.



POWER INPUT CONNECTOR
2 WIRE PIGTAIL

COLOR CODED AMP
3 POSITION SOCKET
STROBE OUTLETS.

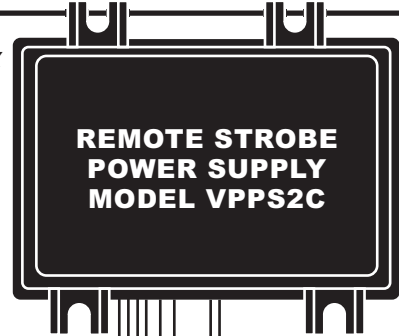

**REMOTE STROBE
POWER SUPPLY
MODEL VPPS2C**

AMP 3
POSITION
MATE N LOK®
CONNECTOR

NOTE: THE ITEMS IN THIS BOX ARE INCLUDED WITH THE LIGHthead. (NOT INCLUDED WITH POWER SUPPLY.)

AMP PINS ARE CRIMPED TO 3 CONDUCTOR CABLE FROM THE REMOTE STROBE LIGHT HEAD ASSEMBLY. AFTER ROUTING CABLE INTO POSITION FIT PINS INSIDE PIN CONNECTOR HOUSING.

RIDGE ON AMP CONNECTOR HOUSING INDICATES POSITION 1.

POSITION 1
RED WIRE
POSITION 2
BLACK WIRE
POSITION 3
WHITE WIRE

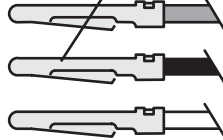
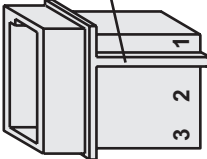

15 FEET OF 3 CONDUCTOR CABLES FROM
REMOTE STROBE LIGHT HEAD ASSEMBLIES.

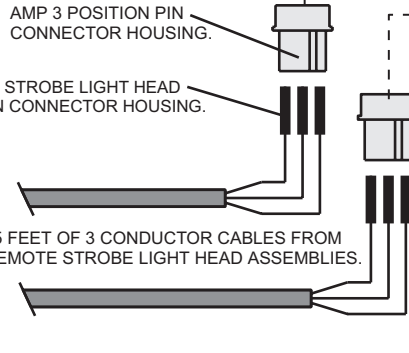

BLACK WIRE IN
POSITION 2 OF
CONNECTOR.
RED WIRE IN
POSITION 1 OF
CONNECTOR.

WIRES OF PIGTAIL
ARE TO BE
CRIMPED TO
INTERCONNECTING
3 CONDUCTOR
CABLE.

**NOTE: IF INPUT
CONNECTOR
POLARITY DOES
NOT MATCH, BUTT
SPlice NEW
CONNECTOR
ASSEMBLY TO
HARNess.**

IMPORTANT NOTE: WHEN CONNECTING THE AMP PINS CRIMPED ON THE WIRES TO THE AMP PIN HOUSING, CAREFULLY NOTE THE COLOR POSITION IN HOUSING.

3 CONDUCTOR
POWER CABLE.
WHITE WIRE TO
BE CUT OFF BY
CUSTOMER ON
BOTH ENDS OF
CABLE.

**NOTE: THE CABLE
ASSEMBLY KIT
SHOWN IN THIS
BOX, IS SUPPLIED
WITH WHELEN
REMOTE PACK
STROBE LIGHT
SYSTEMS ONLY. IT
IS NOT INCLUDED
WITH THE POWER
SUPPLY.**

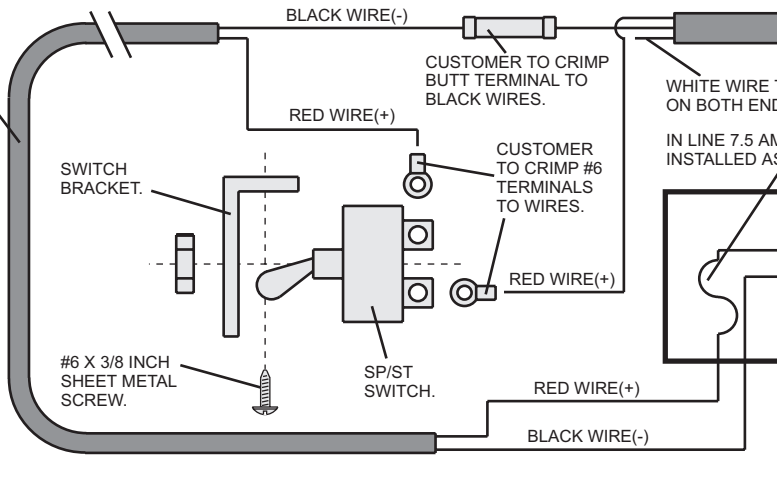

#6 X 3/8 INCH
SHEET METAL
SCREW.

CUSTOMER TO CRIMP
BUTT TERMINAL TO
BLACK WIRES.

WHITE WIRE TO BE CUT FLUSH WITH CABLE JACKET
ON BOTH ENDS OF CABLE BY CUSTOMER.

IN LINE 7.5 AMP FUSE, CUSTOMER SUPPLIED. TO BE
INSTALLED AS CLOSE AS POSSIBLE TO POWER.

