

WHELEN[®]

ENGINEERING COMPANY INC.

Route 145, Winthrop Road,
Chester, Connecticut 06412

Phone: (860) 526-9504

Fax: (860) 526-4078

Internet: www.whelen.com

Sales e-mail: autosale@whelen.com

Canadian Sales e-mail: autocan@whelen.com

Customer Service e-mail: custserv@whelen.com

Installation Guide Model ISP148 Intelligent Strobe Power Supply

Safety First

This document provides all the necessary information to allow your Whelen product to be properly and safely installed. Before beginning the installation and/or operation of your new product, the installation technician and operator must read this manual completely. Important information is contained herein that could prevent serious injury or damage.

- **Proper installation of this product requires the installer to have a good understanding of automotive electronics, systems and procedures.**
- **If mounting this product requires drilling holes, the installer MUST be sure that no vehicle components or other vital parts could be damaged by the drilling process. Check both sides of the mounting surface before drilling begins. Also de-burr any holes and remove any metal shards or remnants. Install grommets into all wire passage holes.**
- **If this manual states that this product may be mounted with tape or Velcro™, clean the mounting surface with a 50/50 mix of isopropyl alcohol and water and dry thoroughly.**
- **Do not install this product or route any wires in the deployment area of your air bag. Equipment mounted or located in the air bag deployment area will damage or reduce the effectiveness of the air bag, or become a projectile that could cause serious personal injury or death. Refer to your vehicle owners manual for the air bag deployment area. The User/Installer assumes full responsibility to determine proper mounting location, based on providing ultimate safety to all passengers inside the vehicle.**
- **For this product to operate at optimum efficiency, a good electrical connection to chassis ground must be made. The recommended procedure requires the product ground wire to be connected directly to the NEGATIVE (-) battery post.**
- **If this product uses a remote device to activate or control this product, make sure that this control is located in an area that allows both the vehicle and the control to be operated safely in any driving condition.**
- **Do not attempt to activate or control this device in a hazardous driving situation.**
- **It is recommended that these instructions be stored in a safe place and referred to when performing maintenance and/or reinstallation of this product.**
- **FAILURE TO FOLLOW THESE SAFETY PRECAUTIONS AND INSTRUCTIONS COULD RESULT IN DAMAGE TO THE PRODUCT OR VEHICLE AND/OR SERIOUS INJURY TO YOU AND YOUR PASSENGERS!**

Selecting a Mounting Location . . .

The logical choice for a mounting area would be a trunk or similar compartment. However, due to the wide variety of vehicles onto which the ISP148 can be installed, this is not always possible. The following guidelines will help the installer select an acceptable alternative:

- A) The unit should be mounted on a metal surface to aid heat dissipation. Be sure that this surface is not one that either generates or is exposed to excessive heat during normal operation of the vehicle.
- B) Do not select a location where the power supply will be exposed to potential damage from any unsecured or loose equipment in the vehicle.
- C) Be sure the area selected will not allow the ISP148 to be exposed to water!
- D) When routing the wires, it is important to choose a path that will keep these wires away from excessive heat and from any vehicle equipment that could compromise the integrity of the wires (ex. trunk lids, door jams, etc.).
- E) Be sure your mounting location does not block the cooling fan in the rear of the unit. (See last page)

WARNING: All customer supplied wires, that connect to the positive (+) terminal of the battery, must be sized to supply at least 125% of the maximum operating current, and fused "at the battery" to carry the load!

WARNING: When extending the communication wires (BLUE & GREY), use either the Whelen 25ft cable (P/N 46-9641638250) or similar "twisted pair" wires!

CAUTION: As it will be necessary to drill holes into the mounting surface, the installer MUST be sure that no vehicle components or other vital parts could be damaged by the drilling process. Check both sides of the mounting surface before drilling begins!

Operating Instructions . . .

The ISP148 has been designed to emulate the operations of four existing Whelen power supplies:

The UPS-188C (Alternating Pairs) - ALT 2X2X4
The DOT-188C (Simultaneous Pairs) - SIMUL. 2X2X4
The DOT-188MN (Simultaneous) - SIMUL. 2X2X4
The BL188C - B-LINK

Selecting the desired operational mode is accomplished by configuring dip switches #1, #2 #3 & #8, located on the front panel of the power supply. The use of Dip Switches #4 & #5 is explained in the "Hi-Lo Power" section. The following section will explain how to place the ISP148 into each of these respective modes, as well as outline the operational procedures for each mode.

Section 1: Emulation Modes . . .

Applying +12VDC to the control wires indicated in each mode (using customer supplied switches) will cause the results indicated. For a listing of the available flash patterns refer to Section 2: Flash Patterns.

ALT. 2X2X4 Mode (Default Configuration) . . .

Dip Switches

The dip switch configuration for UPS188C-mode is:

Dip Switch 1 - OFF Dip Switch 3 - OFF
Dip Switch 2 - OFF Dip Switch 8 - OFF

Control Wires

Control Wire #1 = Outlets 1 & 2 Enabled
Control Wire #2 = Outlets 3 & 4 Enabled
Control Wire #3 = 5, 6, 7 & 8 Enabled

SIM 2X2X4 Mode . . .

Dip Switches

The dip switch configuration for DOT-188C mode is:

Dip Switch 1 - ON Dip Switch 3 - OFF
Dip Switch 2 - OFF Dip Switch 8 - OFF

Control Wires

Control Wire #1 = Outlets 1 & 3 Enabled
Control Wire #2 = Outlets 5 & 7 Enabled
Control Wire #3 = 2, 4, 6 & 8 Enabled

SIM 2X2X4MN Mode . . .

Dip Switches

The dip switch configuration for DOT188MN Mode:

Dip Switch 1 - OFF Dip Switch 3 - OFF
Dip Switch 2 - ON Dip Switch 8 - OFF

Control Wires

Control Wire #1 = Outlets 2 & 4 Enabled
Control Wire #2 = Outlets 6 & 8 Enabled
Control Wire #3 = Outlets 1, 3, 5 & 7 Enabled

ALT 2X2X2X2 Mode . . .

Dip Switches

The dip switch configuration for ALT 2X2X2X2 Mode:

Dip Switch 1 - ON Dip Switch 3 - OFF
Dip Switch 2 - ON Dip Switch 8 - OFF

Control Wires

Control Wire #1 = Outlets 1 & 2 Enabled
Control Wire #2 = Outlets 3 & 4 Enabled
Control Wire #3 = Outlets 5 & 6 Enabled
Control Wire #4 = Outlets 7 & 8 Enabled

NOTE: If Hi/Lo is to be used turn on dip switch 6 and use the pattern 4 control wire.

SIM 2X2X2X2 Mode . . .

Dip Switches

The dip switch configuration for SIM 2X2X2X2 Mode:

Dip Switch 1 - OFF Dip Switch 3 - ON
Dip Switch 2 - OFF Dip Switch 8 - OFF

Control Wires

Control Wire #1 = Outlets 1 & 3 Enabled
Control Wire #2 = Outlets 2 & 4 Enabled
Control Wire #3 = Outlets 5 & 7 Enabled
Control Wire #4 = Outlets 6 & 8 Enabled

NOTE: If Hi/Lo is to be used turn on dip switch 6 and use the pattern 4 control wire.

BL188C Mode . . .

When the ISP148 is configured to emulate the BL188C, it is important to understand that the connections and operational procedures used are quite different from any of the other modes.

Dip Switches

BL188C emulation is accomplished by placing Dip Switch 8 in the ON position. At this point, the remaining Dip Switches (1 thru 3) are used to configure the address of the ISP148 for use in a B-LINK system. The addressing properties function as follows:

To Configure Address 1

Dip Switch 1 - ON
Dip Switch 2 - OFF
Dip Switch 3 - OFF

To Configure Address 2

Dip Switch 1 - OFF
Dip Switch 2 - ON
Dip Switch 3 - OFF

To Configure Address 3

Dip Switch 1 - OFF
Dip Switch 2 - OFF
Dip Switch 3 - ON

Control Wires

In this configuration, control wires 1, 2, 3 & 4 are not used to enable outlets or control Hi/Lo power activation, as with the previous modes. Outlet control and Hi/Lo power activation is handled by the B-LINK Multi-Purpose Controller.

Section 2: Flash Patterns

The ISP148 can generate any of 16 available flash patterns simply activating the 4 Pattern Control wires, either individually or in combination. Table 1 on Page 3 outlines all of the available patterns and the wire activations needed to produce them.

Section 3: Hi/Lo Power

Hi/Lo power activation and functionality can be configured in any of 4 available modes, depending upon how Dip Switches 4 & 5 are positioned. Table 2 on Page 3 outlines each of the 4 configurations and their attributes.

NOTE: In BL188C emulation mode, Hi/Lo power activation is controlled with the B-LINK Multi-Purpose Controller.

Section 4: Diagnostix™ (Optional)

The optional Diagnostix™ display allows the operator to confirm proper operation of not only the 8 outlets on the ISP148, but of the strobe light and strobe cable connected to these outlets as well. Each LED indicator on the Diagnostix™ display, provides diagnostic information for one outlet. For example; LED #1 monitors Outlet #1, etc. The LED's appearance indicates the condition of it's corresponding outlet. Refer to Table 3 on Page 3.

Section 5: Phasing

When you turn dip switch 7 on, you will cause outlets 1-4 to drift slowly in and out of sync with outlets 5-8. Lights will work as described in each mode. The result will be a more eye catching or random flash pattern.

ISP148 WIRING DIAGRAM

UNIT SPECIFICATIONS	
V-INPUT	12.8VDC ±20%
I-IN 12.8V	14 AMPS (TYP)
FLASHRATE	150 FPM (MIN)
JOULES HI	6/2.5/2.5/2.5 (TYP)
JOULES LO	2/2/2/2 (MIN)
OUTPUT POWER	140 WATTS
OUTPUT PER OUTLET	17.5 WATTS (TYP)

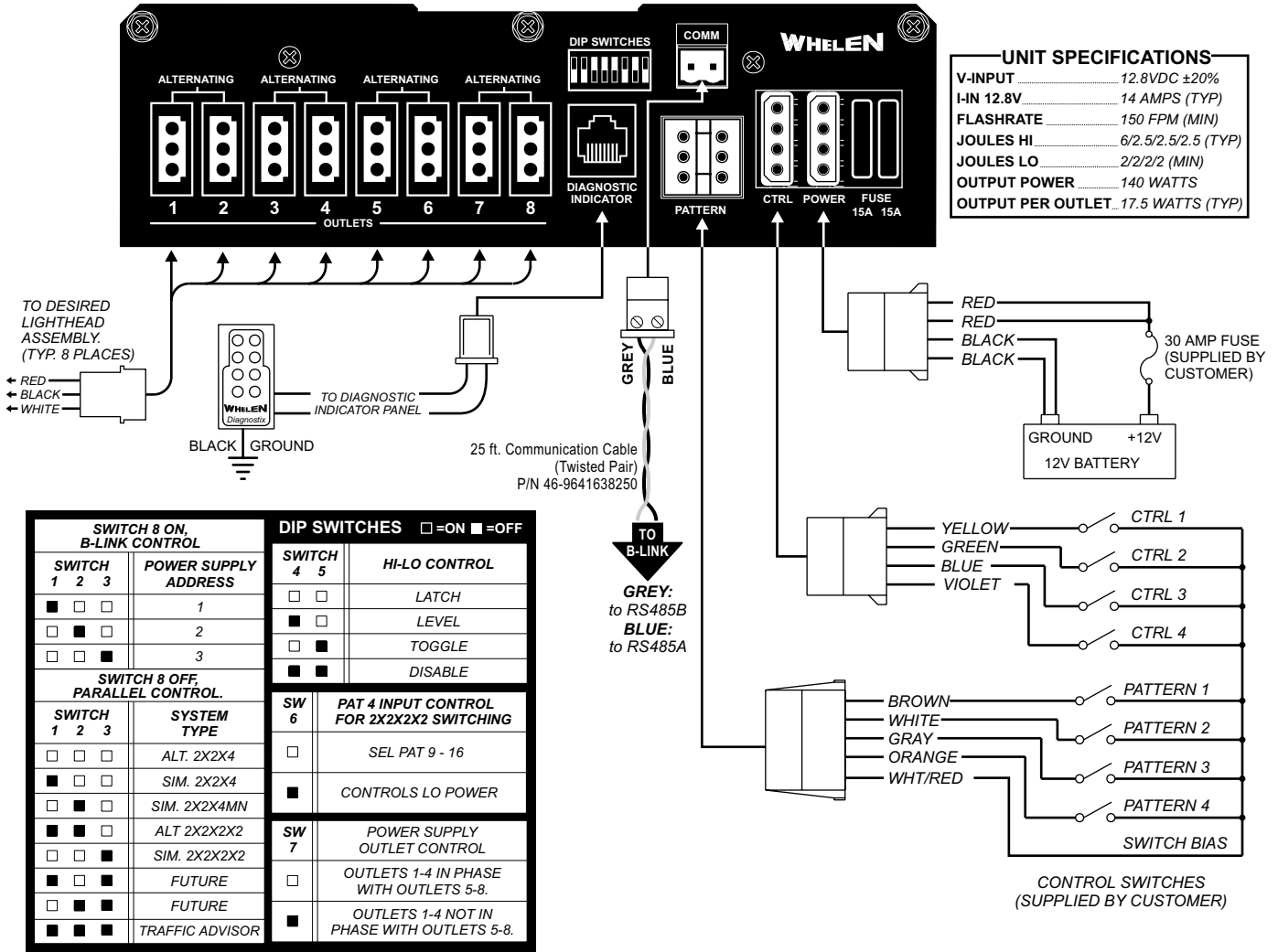

SWITCH 8 ON, B-LINK CONTROL		DIP SWITCHES <input type="checkbox"/> =ON <input type="checkbox"/> =OFF	
SWITCH 1 2 3	POWER SUPPLY ADDRESS	SWITCH 4 5	HI-LO CONTROL
<input checked="" type="checkbox"/> <input type="checkbox"/> <input type="checkbox"/>	1	<input type="checkbox"/> <input type="checkbox"/>	LATCH
<input type="checkbox"/> <input checked="" type="checkbox"/> <input type="checkbox"/>	2	<input checked="" type="checkbox"/> <input type="checkbox"/>	LEVEL
<input type="checkbox"/> <input type="checkbox"/> <input checked="" type="checkbox"/>	3	<input type="checkbox"/> <input checked="" type="checkbox"/>	TOGGLE
<input type="checkbox"/> <input type="checkbox"/> <input type="checkbox"/>		<input checked="" type="checkbox"/> <input checked="" type="checkbox"/>	DISABLE
SWITCH 8 OFF, PARALLEL CONTROL		SW 6	PAT 4 INPUT CONTROL FOR 2X2X2X2 SWITCHING
SWITCH 1 2 3	SYSTEM TYPE	<input type="checkbox"/>	SEL PAT 9 - 16
<input type="checkbox"/> <input type="checkbox"/> <input type="checkbox"/>	ALT. 2X2X4	<input checked="" type="checkbox"/>	CONTROLS LO POWER
<input checked="" type="checkbox"/> <input type="checkbox"/> <input type="checkbox"/>	SIM. 2X2X4	SW 7	POWER SUPPLY OUTLET CONTROL
<input type="checkbox"/> <input checked="" type="checkbox"/> <input type="checkbox"/>	SIM. 2X2X4MN	<input type="checkbox"/>	OUTLETS 1-4 IN PHASE WITH OUTLETS 5-8.
<input checked="" type="checkbox"/> <input checked="" type="checkbox"/> <input type="checkbox"/>	ALT 2X2X2X2	<input checked="" type="checkbox"/>	OUTLETS 1-4 NOT IN PHASE WITH OUTLETS 5-8.
<input type="checkbox"/> <input type="checkbox"/> <input checked="" type="checkbox"/>	SIM. 2X2X2X2		
<input checked="" type="checkbox"/> <input type="checkbox"/> <input checked="" type="checkbox"/>	FUTURE		
<input type="checkbox"/> <input checked="" type="checkbox"/> <input checked="" type="checkbox"/>	FUTURE		
<input checked="" type="checkbox"/> <input checked="" type="checkbox"/> <input checked="" type="checkbox"/>	TRAFFIC ADVISOR		

FLASH PATTERNS: <input type="checkbox"/> = +12VDC	
PATTERN WIRE 1 2 3 4	PATTERN TYPE
<input type="checkbox"/> <input type="checkbox"/> <input type="checkbox"/> <input type="checkbox"/>	COMET FLASH
<input checked="" type="checkbox"/> <input type="checkbox"/> <input type="checkbox"/> <input type="checkbox"/>	TRIPLE FLASH
<input type="checkbox"/> <input checked="" type="checkbox"/> <input type="checkbox"/> <input type="checkbox"/>	DOUBLE FLASH
<input checked="" type="checkbox"/> <input checked="" type="checkbox"/> <input type="checkbox"/> <input type="checkbox"/>	RAPID RANDOM
<input type="checkbox"/> <input type="checkbox"/> <input checked="" type="checkbox"/> <input type="checkbox"/>	SEQUENTIAL
<input checked="" type="checkbox"/> <input checked="" type="checkbox"/> <input checked="" type="checkbox"/> <input type="checkbox"/>	MODU-FLASH
<input type="checkbox"/> <input checked="" type="checkbox"/> <input checked="" type="checkbox"/> <input type="checkbox"/>	MICRO-BURST 2
<input checked="" type="checkbox"/> <input checked="" type="checkbox"/> <input checked="" type="checkbox"/> <input type="checkbox"/>	MICRO-BURST 3
<input type="checkbox"/> <input type="checkbox"/> <input type="checkbox"/> <input checked="" type="checkbox"/>	2X COMET FLASH
<input checked="" type="checkbox"/> <input type="checkbox"/> <input type="checkbox"/> <input checked="" type="checkbox"/>	2X TRIPLE FLASH
<input type="checkbox"/> <input checked="" type="checkbox"/> <input checked="" type="checkbox"/> <input checked="" type="checkbox"/>	2X DOUBLE FLASH
<input checked="" type="checkbox"/> <input checked="" type="checkbox"/> <input type="checkbox"/> <input checked="" type="checkbox"/>	1/2 RAPID RANDOM
<input type="checkbox"/> <input type="checkbox"/> <input checked="" type="checkbox"/> <input checked="" type="checkbox"/>	2X SEQUENTIAL
<input type="checkbox"/> <input checked="" type="checkbox"/> <input checked="" type="checkbox"/> <input checked="" type="checkbox"/>	2X MODU-FLASH
<input type="checkbox"/> <input checked="" type="checkbox"/> <input checked="" type="checkbox"/> <input checked="" type="checkbox"/>	2X MICRO-BURST 2
<input checked="" type="checkbox"/> <input checked="" type="checkbox"/> <input checked="" type="checkbox"/> <input checked="" type="checkbox"/>	2X MICRO-BURST 3
Pattern Wire 1 = BROWN Pattern Wire 2 = WHITE Pattern Wire 3 = GREY Pattern Wire 4 = ORANGE	

Table 2

IF THE LED IS...	THEN...
OFF	Either the outlet in question is not enabled, or the power supply is not turned on.
ON continuously	The outlet, strobe cable and strobe light in question are functioning properly.
FLASHING rapidly	Either the outlet, strobe cable and/or strobe light in question are malfunctioning. In this condition, further investigation of the components is strongly recommended
ON continuously with a single flash every few seconds	The ISP148 is operating in Lo power mode.

Table 3

Hi/Lo Mode Type	Recommended Switch type	To Enable Lo Power Operation	To Restore Hi Power Operation	Dip Switch 4	Dip Switch 5
Latched	Momentary	Apply +12VDC to VIOLET control wire	Turn all strobe outlets off and then on.	OFF	OFF
Level	Single Pole/Single Throw	Apply +12VDC to VIOLET control wire	Remove +12VDC from VIOLET control wire	ON	OFF
Toggle	Momentary	Apply +12VDC to VIOLET control wire	Apply +12 VDC to VIOLET control wire	OFF	ON
DISABLED	NONE	No Low Power Operation in This Mode	Not Applicable	ON	ON

ISP148 REPLACEMENT PARTS

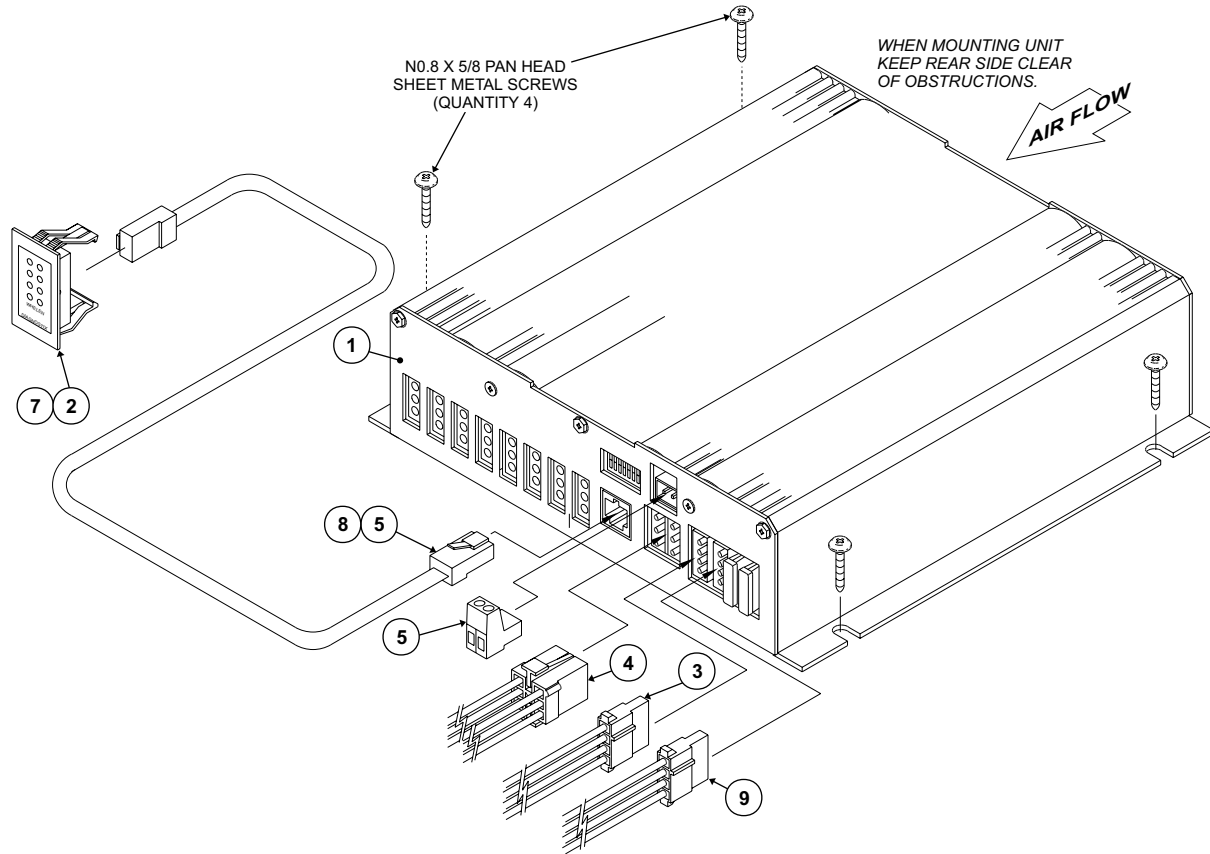

ISP148 PARTS LIST

ITEM	PART NUMBER	DESCRIPTION
REF	46-9641638250	25' TWISTED PAIR B-LINK CABLE
9	46-0725612-00	POWER CONNECTOR ASSEMBLY
8	02-0241485-25	CABLE ASSY, 8 POS TELEPHONE 25'
7	01-0267643-00	DOT DIAGNOSTIC INDICATOR ASSEMBLY
6	02-0241485-08	CABLE ASSY, 8 POS TELEPHONE 8'
5	39CIJ02523-IJ	2 POS PHOENIX CONNECTOR
4	46-0725945-00	PATTERN CONNECTOR ASSEMBLY
3	46-0725613-00	CONTROL CONNECTOR ASSEMBLY
2	01-0267265-00	UPS DIAGNOSTIC INDICATOR ASSEMBLY
1	01-0662811-00	ISP148 FINAL ASSEMBLY
°	01-0683160-00	ISP148 STROBE POWER SUPPLY

Traffic Advisor Mode...

Dip Switches

The dip switch configuration for Traffic Advisor Mode:

- Dip Switch 1 - ON
- Dip Switch 2 - ON
- Dip Switch 3 - ON

Control Wires

In this configuration, applying +12VDC to the control wires (using customer supplied switches) will have the following results:

- Control Wire #1 = LEFT SWEEP**
- Control Wire #2 = RIGHT SWEEP**
- Control Wire #3 = ALTERNATING FLASH**
- Control Wire #2 & #3 = SPLIT SWEEP**

TRAFFIC ADVISOR

In order for the Traffic Advisor patterns to flash properly, it is necessary for the lamps to be connected to the ISP148 in the following pattern.

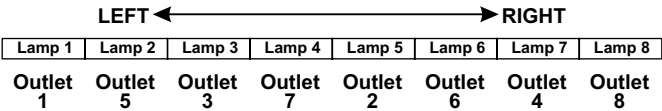

The Traffic Advisor (or T/A) mode is comprised of four, traffic control-oriented flash patterns.

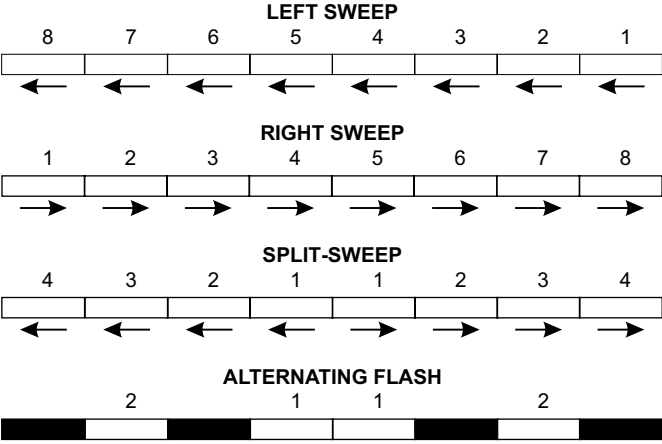

The T/A pattern mode is enabled as indicated in table 2.