

WHELEN[®]

ENGINEERING COMPANY INC.

Route 145, Winthrop Road,
Chester, Connecticut 06412

Phone: (860) 526-9504

Fax: (860) 526-4078

Internet: www.whelen.com

Sales e-mail: autosale@whelen.com

Canadian Sales e-mail: autocan@whelen.com

Customer Service e-mail: custserv@whelen.com

Installation Guide: CSP12180 Strobe Power Supply

Safety First

This document provides all the necessary information to allow your Whelen product to be properly and safely installed. Before beginning the installation and/or operation of your new product, the installation technician and operator must read this manual completely. Important information is contained herein that could prevent serious injury or damage.

- **Proper installation of this product requires the installer to have a good understanding of automotive electronics, systems and procedures.**
- **If mounting this product requires drilling holes, the installer MUST be sure that no vehicle components or other vital parts could be damaged by the drilling process. Check both sides of the mounting surface before drilling begins. Also de-burr any holes and remove any metal shards or remnants. Install grommets into all wire passage holes.**
- **If this manual states that this product may be mounted with suction cups, magnets, tape or Velcro™, clean the mounting surface with a 50/50 mix of isopropyl alcohol and water and dry thoroughly.**
- **Do not install this product or route any wires in the deployment area of your air bag. Equipment mounted or located in the air bag deployment area will damage or reduce the effectiveness of the air bag, or become a projectile that could cause serious personal injury or death. Refer to your vehicle owners manual for the air bag deployment area. The User/Installer assumes full responsibility to determine proper mounting location, based on providing ultimate safety to all passengers inside the vehicle.**
- **For this product to operate at optimum efficiency, a good electrical connection to chassis ground must be made. The recommended procedure requires the product ground wire to be connected directly to the NEGATIVE (-) battery post.**
- **If this product uses a remote device to activate or control this product, make sure that this control is located in an area that allows both the vehicle and the control to be operated safely in any driving condition.**
- **Do not attempt to activate or control this device in a hazardous driving situation.**
- **It is recommended that these instructions be stored in a safe place and referred to when performing maintenance and/or reinstallation of this product.**
- **FAILURE TO FOLLOW THESE SAFETY PRECAUTIONS AND INSTRUCTIONS COULD RESULT IN DAMAGE TO THE PRODUCT OR VEHICLE AND/OR SERIOUS INJURY TO YOU AND YOUR PASSENGERS!**

For warranty information regarding this product, visit www.whelen.com/warranty

Selecting a mounting location:

- The CSP12180 should be mounted on a metal surface to aid heat dissipation. Be sure that this surface is not one that either generates or is exposed to excessive heat during normal operation of the vehicle.
- Do not block the cooling fan located on the top of the unit.
- Do not select a location where the unit will be exposed to potential damage from any unsecured or loose equipment in the vehicle.
- Be sure the area selected will not allow the unit to be exposed to water.
- When routing the units wires, it is important to choose a path that will keep these wires away from excessive heat and from any vehicle equipment that could compromise the integrity of the wires (trunk lids, door jams, etc.).

WARNING! The Strobe Light Power Supply is a high voltage device. Do not touch or remove the strobe tube assembly while in operation. Wait at least 10 minutes after disconnecting the unit from its power source before starting work or troubleshooting on the power supply or system.

Mounting:

1. Position the power supply onto its proposed mounting location to ensure that it fits properly. With the unit in place, insert an awl or other suitable tool into the mounting screw area of the power supply and scribe the areas that are to be drilled.
2. Remove the unit from its mounting area and, using a drill bit sized for a #10 sheet metal screw, drill a hole in each of the areas scribed in the previous step.
3. Return the CSP12180 to its mounting location and using the supplied #10 sheet metal screws, mount the unit onto its mounting surface.

Wiring your CSP12180:

WARNING! All customer supplied wires that connect to the positive terminal of the battery must be sized to supply at least 125% of the maximum operating current and **FUSED** at the battery to carry that load. **DO NOT USE CIRCUIT BREAKERS WITH THIS PRODUCT!**

Note: Although a 30 amp fuse is required to be used in the fuse block, do not install the fuse until *all* of the wire connections are completed.

Wiring: Power

Recommended wire size to extend the power wires:

For 6.9 feet of wire use 16 AWG
For 11 feet if wire use 14 AWG
For 17 feet of wire use 12 AWG
For 27.8 feet of wire use 10 AWG

1. Locate the 4 position power connector included with your CSP12180 and plug it into the port indicated. Splice the two RED wires together and extend them to the vehicle battery.
2. Connect the extended wire to a fuse block (customer supplied) and then to the POSITIVE terminal on the battery.
3. Splice the two BLACK wires together and extend to the vehicle battery. Connect the extended wire to the factory chassis ground adjacent to the battery.

Wiring: Control Connector

Next plug the 6 position control connector into its port and follow the wiring diagram for the connections. Use a minimum of 22 AWG wire to extend the control wires. The wire functions are as follows:

Blue wire: Apply power to this wire and Lamps 1 & 2 will flash alternately with each other.

Green wire: Apply power to this wire and Lamps 3 & 5 will flash alternately with lamps 4 & 6

Yellow wire: Apply power to this wire and Lamps 7 & 9 will flash alternately with each other

Gray wire: Apply power to this wire and Lamps 9 and 11 will flash alternately with 10 and 12.

White wire: This wire controls pattern selection. This is a positive activation input. A momentary activation (Less than 1 second) will cause the power to change the default flash pattern to the next available pattern. If the new pattern is active for more than 1 second, it will become the new default pattern. A momentary activation (more than 1 second) will cause the power supply to change the default flash pattern to the previous pattern. If the input is tied to positive while the unit is powered up, the unit will reset to the factory default pattern (Comet Flash).

Violet wire: This wire controls the HI/LO feature. (see wiring diagram)

SPECIFICATIONS

INPUT VOLTAGE.....12.8 VDC +/-20%
 INPUT CURRENT.....18 AMPS
 INPUT POWER.....230 WATTS
 ANODE VOLTAGE.....450 VDC / MAX
 ENERGY / TOTAL.....6 X 12 JOULES
 ENERGY / HI POWER.....4.4/2.6/2.6/2.6
 ENERGY / LO POWER.....1.6/1.6/1.6/1.6
 OUTPUT POWER.....2 X 90 WATTS
 FLASH RATE / DEFAULT.....150 CFPM +/-5%

FLASH PATTERNS:

- | | |
|------------------|---------------------|
| 1 - COMET FLASH | 6 - MODU-FLASH |
| 2 - TRIPLE FLASH | 7 - MICRO BURST II |
| 3 - DOUBLE FLASH | 8 - MICRO BURST III |
| 4 - RAPID RATE | 9 - LONG BURST |
| 5 - ACTION FLASH | 10 - ACTION SCAN |

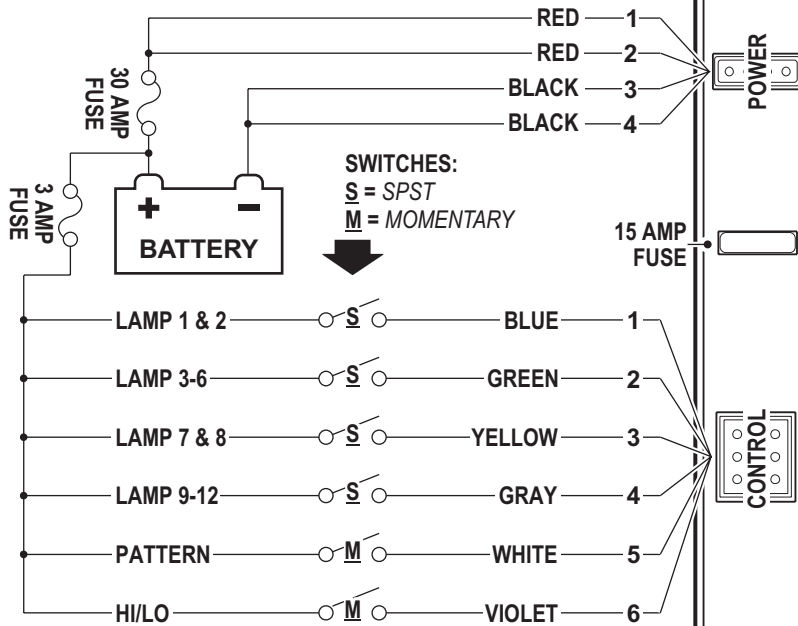

HI/LO FUNCTION:

NOTE - The type of switch used depends on how the operator wants Hi/Lo to function:

Latching Mode: By applying (+) voltage to the Violet wire for less than 1 sec., the power supply is latched into low power operation. The unit must be turned off and then back on to restore normal, Hi power operation. Use a momentary switch for this mode of operation.

Level Mode: Applying +voltage to the Violet wire for more than 1 sec. holds the power supply in low power mode until that voltage is removed. Use a toggle switch for this mode of operation.

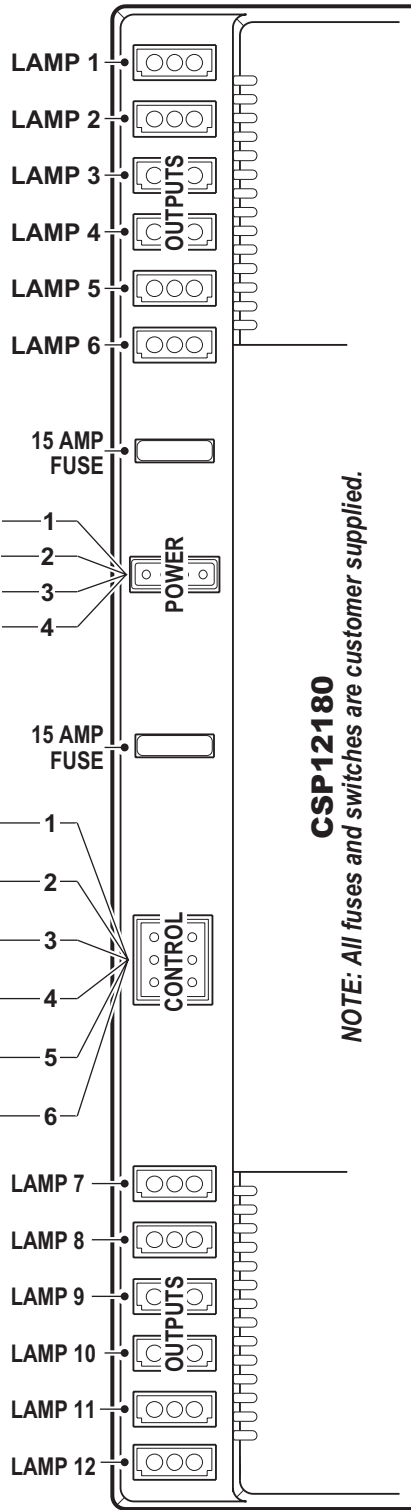

CSP12180
 NOTE: All fuses and switches are customer supplied.