

WHELEN[®]

ENGINEERING COMPANY INC.

51 Winthrop Road
Chester, Connecticut 06412-0684
Phone: (860) 526-9504
Internet: www.whelen.com
Sales e-mail: autosale@whelen.com
Customer Service e-mail: custserv@whelen.com

Installation/Operating Manual:
295HFS6-series Siren

DANGER! Sirens produce extremely loud emergency warning tones! Exposure to these tones without proper and adequate hearing protection, could cause ear damage and/or hearing loss! The Occupational Safety & Health Administration (www.osha.gov) provides information necessary to determine safe exposure times in Occupational Noise Exposure Section 1910.95. Until you have determined the safe exposure times for your specific application, operators and anyone else in the immediate vicinity should be required to wear an approved hearing protection device. Failure to follow this recommendation could cause hearing loss!

Warnings to Installers

Whelen's emergency vehicle warning devices must be properly mounted and wired in order to be effective and safe. Read and follow all of Whelen's written instructions when installing or using this device. Emergency vehicles are often operated under high speed stressful conditions which must be accounted for when installing all emergency warning devices. Controls should be placed within convenient reach of the operator so that they can operate the system without taking their eyes off the roadway. Emergency warning devices can require high electrical voltages and/or currents. Properly protect and use caution around live electrical connections. Grounding or shorting of electrical connections can cause high current arcing, which can cause personal injury and/or vehicle damage, including fire. Many electronic devices used in emergency vehicles can create or be affected by electromagnetic interference. Therefore, after installation of any electronic device it is necessary to test all electronic equipment simultaneously to insure that they operate free of interference from other components within the vehicle. Never power emergency warning equipment from the same circuit or share the same grounding circuit with radio communication equipment. All devices should be mounted in accordance with the manufacturer's instructions and securely fastened to vehicle elements of sufficient strength to withstand the forces applied to the device. Driver and/or passenger air bags (SRS) will affect the way equipment should be mounted. This device should be mounted by permanent installation and within the zones specified by the vehicle manufacturer, if any. Any device mounted in the deployment area of an air bag will damage or reduce the effectiveness of the air bag and may damage or dislodge the device. Installer must be sure that this device, its mounting hardware and electrical supply wiring does not interfere with the air bag or the SRS wiring or sensors. Mounting the unit inside the vehicle by a method other than permanent installation is not recommended as unit may become dislodged during swerving; sudden braking or collision. Failure to follow instructions can result in personal injury. Whelen assumes no liability for any loss resulting from the use of this warning device. PROPER INSTALLATION COMBINED WITH OPERATOR TRAINING IN THE PROPER USE OF EMERGENCY WARNING DEVICES IS ESSENTIAL TO INSURE THE SAFETY OF EMERGENCY PERSONNEL AND THE PUBLIC.

Warnings to Users

Whelen's emergency vehicle warning devices are intended to alert other operators and pedestrians to the presence and operation of emergency vehicles and personnel. However, the use of this or any other Whelen emergency warning device does not guarantee that you will have the right-of-way or that other drivers and pedestrians will properly heed an emergency warning signal. Never assume you have the right-of-way. It is your responsibility to proceed safely before entering an intersection, driving against traffic, responding at a high rate of speed, or walking on or around traffic lanes. Emergency vehicle warning devices should be tested on a daily basis to ensure that they operate properly. When in actual use, the operator must ensure that both visual and audible warnings are not blocked by vehicle components (i.e.: open trunks or compartment doors), people, vehicles, or other obstructions. It is the user's responsibility to understand and obey all laws regarding emergency warning devices. The user should be familiar with all applicable laws and regulations prior to the use of any emergency vehicle warning device. Whelen's audible warning devices are designed to project sound in a forward direction away from the vehicle occupants. However, because sustained periodic exposure to loud sounds can cause hearing loss, all audible warning devices should be installed and operated in accordance with the standards established by the National Fire Protection Association.

Safety First

This document provides all the necessary information to allow your Whelen product to be properly and safely installed. Before beginning the installation and/or operation of your new product, the installation technician and operator must read this manual completely. Important information is contained herein that could prevent serious injury or damage.

⚠ WARNING: This product can expose you to chemicals including Lead which is known to the State of California to cause cancer and birth defects or other reproductive harm. For more information go to www.P65Warnings.ca.gov.

- Proper installation of this product requires the installer to have a good understanding of automotive electronics, systems and procedures.
- Whelen Engineering requires the use of waterproof butt splices and/or connectors if that connector could be exposed to moisture.
- Any holes, either created or utilized by this product, should be made both air- and watertight using a sealant recommended by your vehicle manufacturer.
- Failure to use specified installation parts and/or hardware will void the product warranty.
- If mounting this product requires drilling holes, the installer MUST be sure that no vehicle components or other vital parts could be damaged by the drilling process. Check both sides of the mounting surface before drilling begins. Also de-burr the holes and remove any metal shards or remnants. Install grommets into all wire passage holes.
- If this manual states that this product may be mounted with suction cups, magnets, tape or Velcro®, clean the mounting surface with a 50/50 mix of isopropyl alcohol and water and dry thoroughly.
- Do not install this product or route any wires in the deployment area of your air bag. Equipment mounted or located in the air bag deployment area will damage or reduce the effectiveness of the air bag, or become a projectile that could cause serious personal injury or death. Refer to your vehicle owner's manual for the air bag deployment area. The User/Installer assumes full responsibility to determine proper mounting location, based on providing ultimate safety to all passengers inside the vehicle.
- For this product to operate at optimum efficiency, a good electrical connection to chassis ground must be made. The recommended procedure requires the product ground wire to be connected directly to the NEGATIVE (-) battery post (this does not include products that use cigar power cords).
- If this product uses a remote device for activation or control, make sure that this device is located in an area that allows both the vehicle and the device to be operated safely in any driving condition.
- It is recommended that these instructions be stored in a safe place and referred to when performing maintenance and/or reinstallation of this product.
- FAILURE TO FOLLOW THESE SAFETY PRECAUTIONS AND INSTRUCTIONS COULD RESULT IN DAMAGE TO THE PRODUCT OR VEHICLE AND/OR SERIOUS INJURY TO YOU AND YOUR PASSENGERS!

**ACTIVATION OF THIS
SIREN MAY DAMAGE
UNPROTECTED EARS!**



CAUTION

Loud siren noise can cause hearing damage and/or loss. Refer to OSHA Section 1910.95 prior to putting ANY siren into service!

WARNING!

DISCONNECTING THE VEHICLE BRAKE LAMP CIRCUIT USING ANY SIRENS WITH RELAY OUTPUTS OR SWITCH CONTROLLERS COULD CAUSE VEHICLE OR PROPERTY DAMAGE, SERIOUS INJURY OR EVEN DEATH.

DISABLING THIS CIRCUIT IS A VIOLATION OF THE FEDERAL MOTOR VEHICLE SAFETY STANDARD FOR THE THIRD BRAKE LIGHT, AS WELL AS REAR BRAKE LIGHTS.

FUNCTIONS THAT BLACK OUT THE REAR BRAKE LIGHTS (SOMETIMES CALLED “BRAKE LIGHT CUT OUT”) MAY INTERFERE WITH THE BRAKE SHIFT LOCK MECHANISM, AND CAUSE THE VEHICLE TO MOVE UNEXPECTEDLY AND DANGEROUSLY.

DISCONNECTING THE BRAKE LIGHTS IN ANY WAY IS AT YOUR OWN RISK AND IS NOT RECOMMENDED BY WHELEN.

Installation...

The 295HFS6, although technologically advanced, is simple to install. An aftermarket center console is recommended for the mounting location of the 295HFS6. This not only allows the driver to reach the controls easily, but also keeps the unit safely out of the path of the vehicle's SRS air-bag. Follow the console manufacturer's instructions for mounting information. If a console-type mount is not possible, the 295HFS6 includes a bail strap mounting kit for over- or under-dash mounting.

Important Note! If dash mounting is chosen, the installer **must** confirm that the unit is not being installed in an air-bag deployment zone. Failure to do so could result in the interference of the air-bag's ability to function properly. The air-bag deployment zones can be found in the vehicle's owner manual. The same precautions apply when selecting the microphone hanger location.

The following steps will guide you through the installation process:

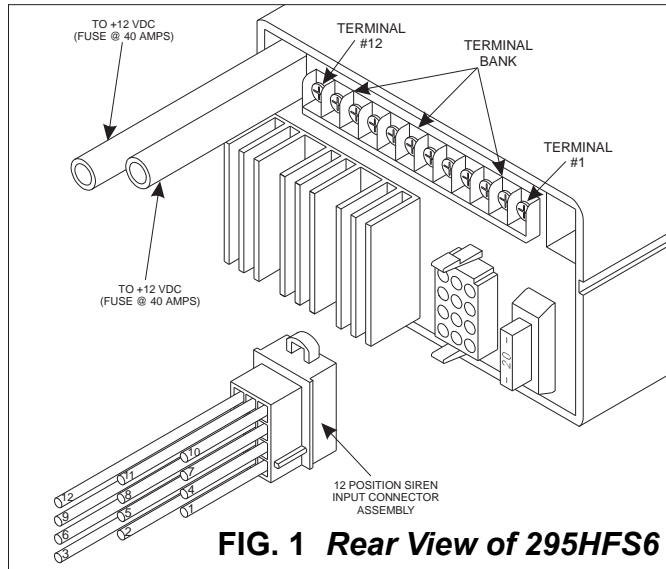

READ BEFORE INSTALLING!!!

Do not install this product or route any wires in the deployment area of your airbag. Equipment mounted or located in the airbag deployment area will damage or reduce the effectiveness of the airbag, or become a projectile that could cause serious personal injury or death. Refer to your vehicle owners manual for the air bag deployment area.

The User/Installer assumes full responsibility to determine proper mounting location, based on providing ultimate safety to all passengers inside the vehicle. Whelen Engineering Company assumes no liability or responsibility for determining individual applications or exact installation location criteria.

Connections For The 12 Position Input Harness

Connecting The Power & Ground wires (Red and Black)

1. Remove the driver's side front seat.
2. Remove the front, driver's side rocker sill plate and kick panel.
3. Fold back the floor covering so that access is gained to the factory wire harness routed under the driver's seat area.
4. Insert the wiring harness into it's port as shown in Fig. 1.
5. Extend the two RED and two BLACK wires, from the 12-position connector on the rear panel of the 295HFS6, toward the sill plate location. Follow the same path as the factory wire harness.

WARNING: *All customer supplied wires that connect to the POSITIVE (+) terminal of the battery must be sized to supply at least 125% of the maximum operating current and be fused "at the battery" to carry that load!*

6. Continue to follow the factory harness through the firewall. To pass the RED and BLACK wires through, it may be necessary to drill a hole in the firewall. If so, be absolutely sure that there are no components that could be damaged by drilling. After the hole is drilled, insert a grommet to protect the wires.
7. Route the RED and BLACK wires along the factory harness towards the battery.
8. Install a 20 amp fuse block (user supplied) on the end of the RED wires.

NOTE: Remove the fuse from the fuse block before connecting any wires to the battery!

9. Connect the fuse block wire to the POSITIVE (+) terminal on the battery. There must not be more than two (2) feet of wire between the fuse block and the battery. As the wire between the fuse and the battery is “unprotected”, do not allow this wire to come in contact with any other wires!
10. Connect the BLACK wire to the factory chassis ground, adjacent to the battery.

Connecting The 295HFS6 Speaker Wires (Yellow, Orange & Brown)

NOTE:This section outlines a two-speaker installation. If a one-speaker installation is used, cut and cap the ORANGE wire, skip steps 3 & 5 and connect the BROWN wire to the NEGATIVE terminal of speaker #1.

1. Route the YELLOW, ORANGE and BROWN wires toward the vehicle’s siren speakers.
2. Connect the YELLOW wire to the POSITIVE speaker connection on speaker #1.
3. Connect the ORANGE wire to the POSITIVE speaker connection on speaker #2.
4. Connect the BROWN wire to the NEGATIVE speaker connection on speaker #2.
5. Splice a wire from the NEGATIVE speaker connection on speaker #2 to the NEGATIVE speaker connection on speaker #1.

(Optional) Connecting The 295HFS6 Horn Relay Wires (White & Grey)

1. Route the WHITE and GREY wires along the factory wire harness and through the firewall at the same point as the RED and BLACK wires.
2. Locate your vehicle’s horn relay and route the WHITE and GREY wires to this. If possible, follow the factory wire harness to this relay.
3. Locate the wire that connects the vehicle horn to the horn relay. Cut this wire.
4. Connect the WHITE wire to the wire coming from the horn relay.
5. Connect the GREY wire to the wire coming from the horn.

NOTE:The two (2) BLUE wires are used to connect your two-way radio’s external speaker to the 295HFS6 for radio re-broadcast. This is an optional connection and does not effect the other operations of the 295HFS6.

(Optional) Wiring The 295HFS6 Radio Rebroadcast wires (BLUE)

1. Locate the two wires that connect the external speaker to the vehicle’s two-way radio.
2. Cut one of these wires and splice one of the BLUE wires into this circuit.
3. Cut the remaining speaker wire and splice the remaining BLUE wire into this circuit.

NOTE:Radio re-broadcast will NOT work with amplified remote speakers! If your remote speaker is amplified (Contains a power amp circuit in the speaker assembly), do not enable the radio re-broadcast feature.

(Optional) Wiring The 295HFS6 For Park-Siren-Kill (Violet)

The 295HFS6 can be configured to cease all siren tones whenever the vehicle’s transmission is in park. This feature is automatically enabled when the VIOLET wire is connected to the transmission’s neutral safety switch. If this feature is not desired, cut and cap the VIOLET wire.

12 POSITION INPUT CONNECTOR ASSEMBLY

HOUSING POSITION	COLOR	FUNCTION
1	RED	BATTERY (POS.)
2	BLACK	CHASSIS GROUND
3	BLUE	TWO-WAY RADIO (OPTIONAL)
4	RED	BATTERY (POS.)
5	BLACK	CHASSIS GROUND
6	BLUE	TWO-WAY RADIO (OPTIONAL)
7	BROWN	SPEAKER #1 (NEG.)* SPEAKER #2 (NEG.)**
8	ORANGE	SPEAKER #2 (POS.)
9	VIOLET	AUX. ENABLE
10	GRAY	TO VEHICLE HORN
11	WHITE	TO HORN RELAY
12	YELLOW	SPEAKER #1 (POS.)

*=CONNECT TO SPEAKER #1 WHEN A SINGLE SPEAKER INSTALLATION IS USED
 **=CONNECT TO SPEAKER #2 WHEN A DUAL SPEAKER INSTALLATION IS USED

Connections For The 12 Terminal Input Connections

NOTE: The push-button and slide switch control terminals are designed to activate components with a load rating no higher than 10 amps each. Terminal outputs 3, 4 & 5 can be ganged (grouped) to handle a 30 amp component.

Connecting Components For Slide-Switch Control...

1. Route and connect the desired component wire to Terminal #1.
2. Route and connect the desired component wire to Terminal #2.
3. Route and connect the desired component wire(s) to Terminal's #3, 4 & 5 (30 amps).

NOTE: Terminals #3, 4 & 5 can have a component connected to each of these terminals. It is important to understand that these three terminals can not be turned on individually! However a high-amperage component (no greater than 30 amps) can be controlled by the 295HFS6 if these three terminals are spliced together and connected to the component.

Configuring The Slide-Switch Control Functions...

In the default configuration (as shipped from the factory), the slide switch is configured as follows:

Slide Position #0No Terminal active

Slide Position #1Terminal #1= ACTIVE, Terminal #2= inactive, Terminals #3, 4 & 5= inactive

Slide Position #2Terminal #1= inactive, Terminal #2= ACTIVE, Terminals #3, 4 & 5= inactive

Slide Position #3Terminal #1= inactive, Terminal #2= inactive, Terminals #3, 4 & 5= ACTIVE

The slide switch configuration can be altered so that any combination of these terminals may be active or inactive in any of the three functioning slide positions. The slide switch configurations are controlled by two Dip Switch banks which are located on the top circuit board of the 295HFS6.

Before proceeding, disconnect all the input harness connectors from the rear of the 295HFS6. Access to the Dip Switch banks is gained by removing four small phillips-head screws located at the four corners of the 295HFS6 face plate. With these screws removed, slide the chassis housing cover towards the rear of the 295HFS6. It is not necessary to slide this cover more than a few inches, as the Dip Switch banks are located just behind the control panel.

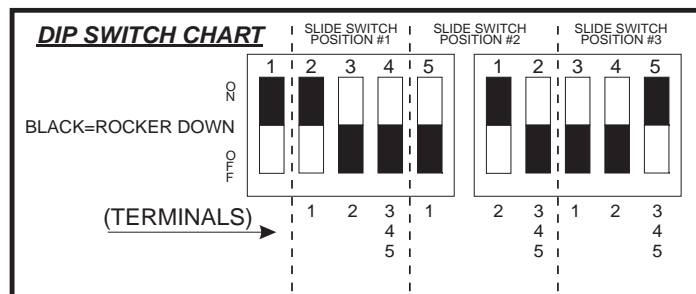

The Dip Switch Chart illustrates how the dip switches are configured. As shown, the configuration for slide switch position #1 is controlled by dip switch #'s 2, 3 & 4 on bank 1. Dip switch #2 (which controls Terminal #1) is in the ON position, while #3 (Terminal #2) & #4 (Terminals #3, 4 & 5) are in the off position. This means that when the slide switch is moved to position #1, Terminal #1 alone becomes active.

Slide switch position #2 is controlled by dip switch #5 on bank 1, and by dip switch #1 and #2 on bank 2. In the default configuration, dip switch #5 (Terminal #1) is off, dip switch #1 (Terminal #2) is ON and dip switch #2 (Terminals #3, 4 & 5) is off. This means that when the slide switch is moved to position #2, Terminal #2 alone is active, while Terminal #1 and Terminals 3, 4 & 5 are inactive.

Slide switch position #3 is controlled by dip switch #'s 3, 4 & 5 on bank 2. In the default configuration, dip switch #3 (Terminal #1) is off, dip switch #4 (Terminal #2) is off and dip switch #5 (Terminals #3, 4 & 5) is ON. This means that when the slide switch is moved to position #3, Terminals #3, 4 & 5 are active, while Terminals #1 & #2 are inactive.

Enabling Siren Tones through Slide Switch Position #3...

Slide switch position #3 is configured to automatically activate siren tones (in it's default configuration). If this is not desired, make sure that dip switch #1 on bank 1 is in the off position. Please note that siren

activation through slide switch position #3 is only available when the power switch is in the ON position.

Backlighting

Backlighting for the six push buttons may be controlled in one of two manners: In the default (as shipped) mode, terminal number 12 of the barrier strip controls the backlighting. Depending on the customers preference terminal 12 may be connected to the vehicles dash light circuit or to an ignition on accessory connection.

For vehicles utilizing a battery disconnect switch an internal jumper may be moved, allowing the backlighting to be controlled by power applied to the number 10 AWG input wires, saving an additional connection.

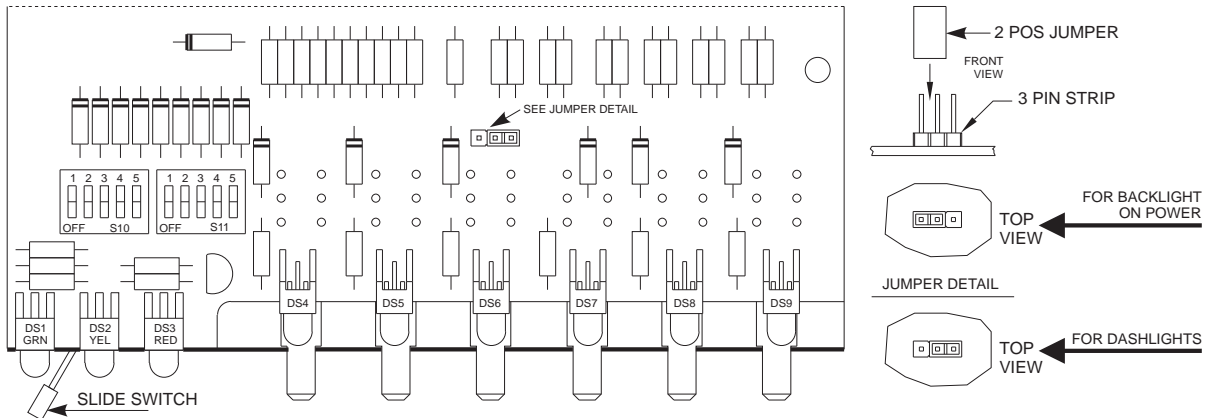

Connecting To The Push-Button Switch Control Terminals:

The 295HFS6 push button switches control the following Terminals:

- P-BUTTON #1 Terminal #6
- P-BUTTON #2 Terminal #7
- P-BUTTON #3 Terminal #8
- P-BUTTON #4 Terminal #9
- P-BUTTON #5 Terminal #10
- P-BUTTON #6 Terminal #11

(NOTE: p-button #6 is a momentary switch. This switch is best used for momentary-use circuits such as trunk release or gun lock)

Connections For Power

- RED (10 GA) to POSITIVE (+) battery terminal (Fuse @ 40 amps.)
- RED (10 GA) to POSITIVE (+) battery terminal (Fuse @ 40 amps.)

295HFS6 WIRING SCHEMATIC

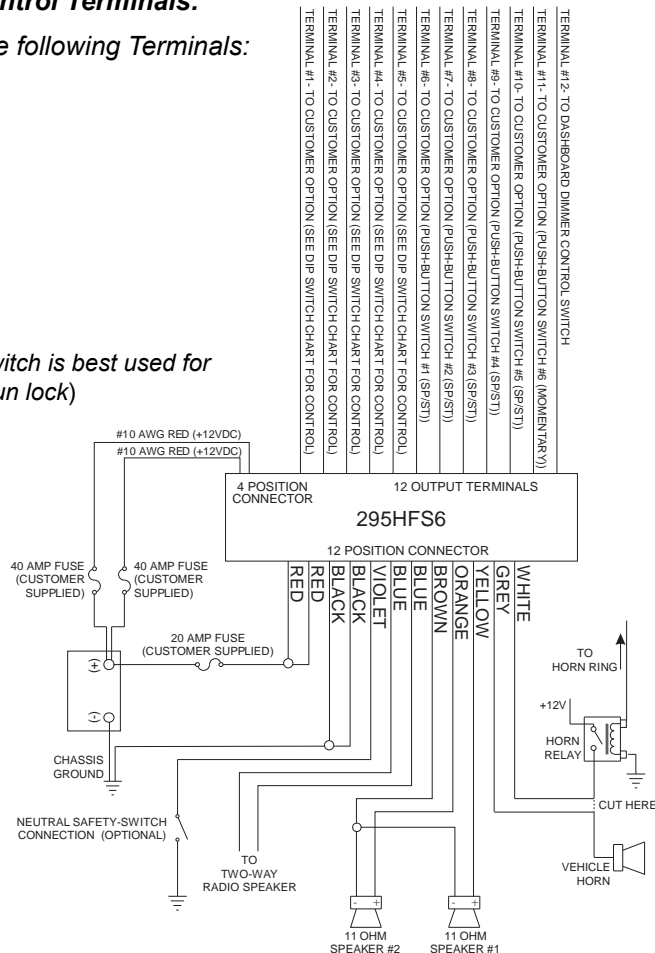

To Adjust the Radio Repeat Levels:

Before using the 295HFS6, the Radio Repeat output volume must be adjusted to satisfactory operating levels. To adjust this level, a small, flat blade screwdriver is needed.

Radio Repeat Volume

Locate the Radio Repeat adjustment port (potentiometer) to the right of the rotary knob. Set the volume level of the vehicle's two-way radio to its normal operating volume. Turn the Rotary Knob to RAD to activate Radio Repeat. Insert the screwdriver in the Radio Repeat adjustment port and turn in a clockwise direction to increase the sound to its maximum desired volume.

Microphone Volume Knob (PA)

Locate the Microphone adjustment knob above the microphone cord. With the vehicle in an enclosed area, turn the Rotary Knob to PA and speak into the microphone. While speaking, turn the volume knob in a clockwise direction to increase the volume. Continue to increase the PA volume until audio feedback occurs. Turn the knob in a counter-clockwise direction to eliminate feedback and set the PA level to maximum volume

Operating the 295HFS6 controls...

Power Switch

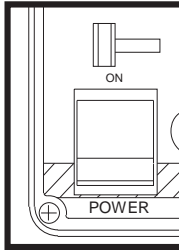

This switch has two positions: Down (295HFS6 - Off) and Up (295HFS6 - On). When this switch is in the Off position, the WS295HFS will not function. When the switch is in the On position the siren is functional and may be activated at the operator's discretion. *NOTE: If the 295HFS6 is connected to the vehicle's horn ring circuit, the vehicle horn is disable when the 295HFS6 power switch is in the ON position.*

MAN Button

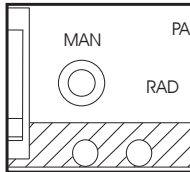

The Manual button generates a variety of tones, depending on what position the Rotary knob is in. For further explanation of this button's function, refer to the Rotary knob section of this manual.

Rotary Switch

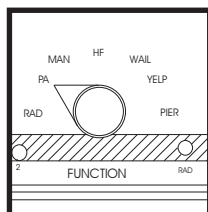

The Rotary Knob controls the siren and PA (Public Address) functions of the 295HFS6. There are 7 positions that may be selected. Each position and its function is outlined below:

RAD (Radio Repeat) - When the rotary knob is in the RAD position, any signal that is received by the vehicle's two-way radio will be simultaneously broadcast over the vehicle's loudspeaker (the 295HFS6 must be connected to the two-way radio as outlined in this manual). This function overrides any other siren function.

PA (Public Address) - When the rotary knob is in the PA position, public address functions are operational. Messages may be broadcast over the vehicle's loudspeaker when the 295HFS6 microphone is in use. The volume level of PA transmissions is controlled by the volume knob. If the Manual button is pressed while the rotary knob is in this position, an "air horn" siren tone will be generated by your vehicle's loudspeaker. This tone is generated until the Manual button is released. The "air horn" may also be generated by pressing the vehicle's steering wheel horn button (if the vehicle's horn has been wired to the 295HFS6).

MAN (Manual Siren) - When the rotary knob is in the MAN position, pressing the Manual button generates a tone that rises in pitch to a pre-set level. This tone is generated for as long as the Manual button is pressed. The same tone may be generated by pressing the vehicle's steering wheel horn button (if the vehicle's horn has been wired to the 295HFS6). Please note that the 295HFS6 microphone will override the siren function. The MAN button is also used to activate the SI-TEST® cycle. See the SI-TEST® section on the following page for details on this important function.

HF (Hands Free Operation) - When the rotary knob is in the HF position, the siren functions of the 295HFS6 are placed in a stand-by mode. Siren tones are activated by a single "tap" on the MAN button or a single "tap" on the vehicle's steering wheel horn button (if the vehicle's horn has been wired to the 295HFS6). The first "tap" produces a "Wail" tone (a steady, rise and fall tone). A second "tap" produces a "Yelp" tone (a fast, rise and fall tone). A third "tap" produces a "Piercer™" tone (an extremely fast, rise and fall tone). The next "tap" returns the siren to a "Wail" tone and the cycle repeats itself. Two quick, successive "taps" will stop the siren.

WAIL (Wail Tone) - When the rotary knob is in the WAIL position, a steady, rise and fall tone is produced. A single "tap" on the MAN button or a single "tap" on the vehicle's steering wheel horn button (if the vehicle's horn has been wired to the 295HFS6), changes the siren tone to a "Yelp" pattern (a fast, rise and fall tone). A second "tap", and the siren returns to a "Wail" tone. Please note that the 295HFS6 microphone will override the siren function.

YELP (Yelp Tone) - When the rotary knob is in the YELP position, a fast, rise and fall tone is produced. Pressing the MAN button or the vehicle's steering wheel horn button (if the vehicle's horn has been wired to the 295HFS6), changes the siren tone to a simulated air horn tone for as long as the button is pressed. Releasing the button causes the siren to return to the Yelp tone. Please note that the 295HFS6 microphone will override the siren function.

PIER (Piercer™ Tone) - (NOTE: Some models may have a Hi/Lo tone instead of the Piercer™ tone) When the rotary knob is in the PIER/Hi-Lo position, an extremely fast, rise and fall tone (alternating high and low tones for Hi-Lo) is produced. Pressing the MAN button or a single "tap" on the vehicle's steering wheel horn button (if the vehicle's horn has been wired to the 295HFS6), changes the siren tone to a simulated air horn tone for as long as the button is pressed. Releasing the button causes the siren to return to the "Piercer™" (Hi-Lo) tone. Please note that the 295HFS6 microphone will override the siren function.

SI-TEST®

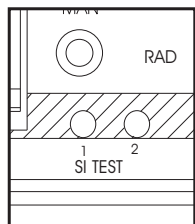

SI-TEST® is a diagnostic feature of the 295HFS6 and allows the operator to confirm the proper operation of the siren speakers connected to the 295HFS6 without activating an audible siren tone. To initiate the SI-TEST® cycle, set the rotary knob to the RAD position. Now press and hold the MAN button for at least 5 seconds. As the siren is tested, its diagnostic indicator will turn on if no problems are detected. If the indicator doesn't light, a problem with either the siren or its connectors has been detected. Check

the wire connections for the failed speaker and repeat SI-TEST®. If the speaker fails the test again, have the siren itself inspected by a qualified technician. **NOTE:** *Installed speakers are tested by generating an ultra-high frequency tone through each speaker. Although these tones are inaudible to humans, be sure that there is nobody within at least 5 feet of the vehicle's speakers when SI-TEST® is running.*

295HFS6 SPECIFICATIONS

INPUT VOLTAGE 12.5 VDC \pm 20%
INPUT CURRENT @15 VDC @ 5.5 OHMS. 16 AMPS MAX.
INPUT FUSE 20 AMPS
SPEAKER IMPEDANCE 5.5 OHMS MIN.
OPERATING TEMPERATURE -30° C. TO +60° C.
STORAGE TEMPERATURE -40° C. TO +70° C.
HUMIDITY 99% (NON CONDENSING)



SIREN (SQUARE WAVE)

<u>TONES</u>	<u>SIREN FREQUENCY</u>	<u>SWEEP RATE</u>
WAIL	800 TO 1600 Hz	12 CYCLES PER MIN.
YELP	800 TO 1600 Hz	180 CYCLES PER MIN.
PIERCER	800 TO 1600 Hz	800 CYCLES PER MIN.
AIR HORN	COMPOSITE	CONSTANT
HI-LO (OPTIONAL)	550 TO 650 Hz	60 CYCLES PER MIN.

OUTPUT VOLTAGE @ 15 VDC @ 11 OHMS 32 V RMS MAX.
OUTPUT POWER @ 15 VDC @ 11 OHMS 105 WATTS MAX.
OUTPUT POWER @ 15 VDC @ 5.5 OHMS 185 WATTS MAX.

AUDIO (SINE WAVE)

AUDIO BANDWIDTH @ 25 WATTS 300 Hz TO 10 KHz \pm 3db
DISTORTION @ 25 WATTS @ 1 KHz 1% MAX.
OUTPUT VOLTAGE @ 15 VDC @ 11 OHMS 24 VRMS MAX.
OUTPUT POWER @ 15 VDC @ 11 OHMS 50 WATTS
RADIO INPUT LEVEL @ R44 MAX. @24 VRMS +10db \pm 3db

SI TEST - RADIO/MANUAL BUTTON

FREQ. - 18 KHz

User Replaceable Parts List

<u>DESCRIPTION</u>	<u>PART NUMBER</u>
12 Position Connector Harness.	46-0745665-00
9 Position Connector Harness.	46-0745796-00
4 Position Connector Harness.	46-0725684-00
Mounting Strap	07-241559-000
Microphone Hanger Kit	01-0415852-00

