

# WHELEN<sup>®</sup>

ENGINEERING COMPANY INC.

51 Winthrop Road


Chester, Connecticut 06412-0684

Phone: (860) 526-9504

Internet: [www.whelen.com](http://www.whelen.com)

Sales e-mail: [lowsales@whelen.com](mailto:lowsales@whelen.com)

Customer Service e-mail: [iowserv@whelen.com](mailto:iowserv@whelen.com)

 **WARNING:** This product can expose you to chemicals including Methylene Chloride which is known to the State of California to cause cancer, and Bisphenol A, which is known to the State of California to cause birth defects or other reproductive harm. For more information go to [www.P65Warnings.ca.gov](http://www.P65Warnings.ca.gov).

# WPS-4000 SERIES HIGH POWER VOICE & SIREN SYSTEM

## INSTALLATION MANUAL

**Mass Notification**

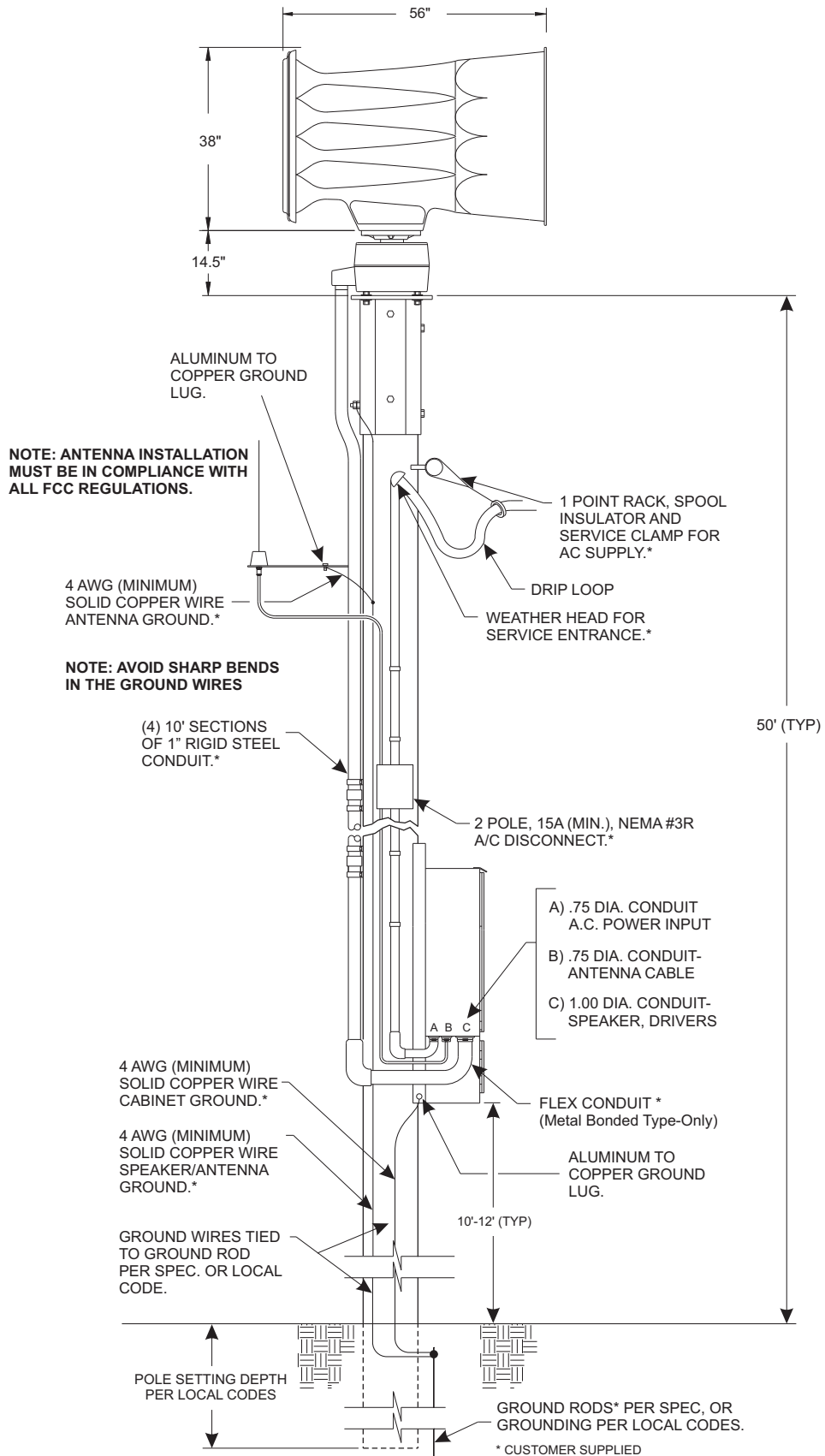
# Table Of Contents

|  |         |
|--|---------|
| Important Note To Installation Technicians ..... | page 5  |
| Section I : Site Selection .....                 | page 6  |
| Section II: Utility Pole Preparation             |         |
| a) Pole Selection.....                           | page 7  |
| b) Component Dimensions .....                    | page 7  |
| Section III: Equipment Mounting                  |         |
| a) Pole Top Mounting Bracket .....               | page 12 |
| b) Electronic Cabinet Mounting .....             | page 14 |
| c) Siren Assembly Mounting .....                 | page 16 |
| d) Antenna Mounting (optional) .....             | page 18 |
| e) Solar Panel Mounting (optional) .....         | page 19 |
| f) Determining Solar Panel Mounting Angle .....  | page 22 |
| Section IV: Wiring                               |         |
| a) Siren Connections .....                       | page 23 |
| b) AC Wiring .....                               | page 25 |
| c) Batteries .....                               | page 27 |
| d) Landline.....                                 | page 30 |
| Section V: System Test.....                      | page 31 |

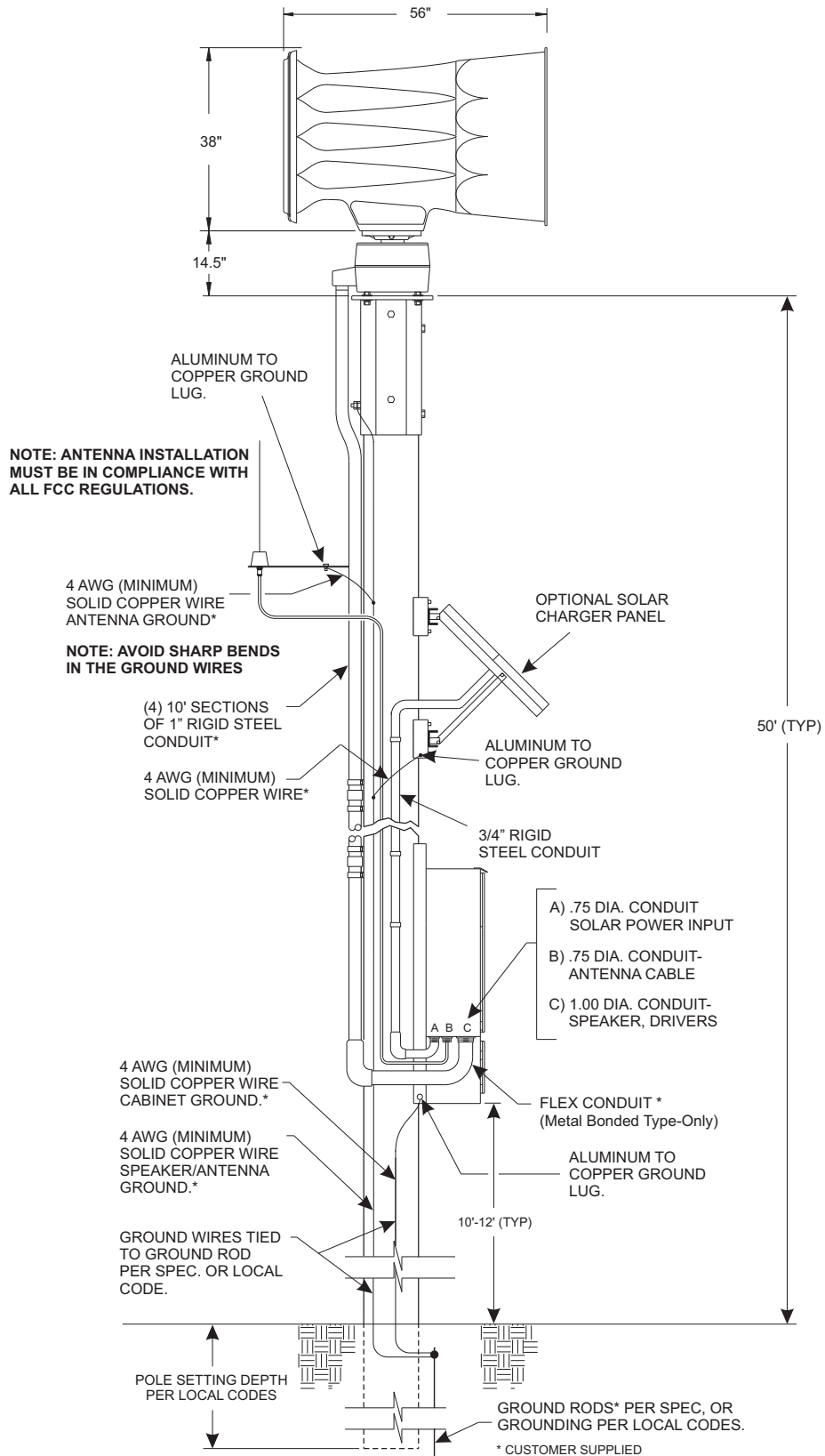
## Illustrations

|   |         |
|---|---------|
| Fig. 1 Station Drawing .....                                | page 3  |
| Fig. 2 Station Drawing (with optional Solar Panel) .....    | page 4  |
| Fig. 3 Pole Top Mounting Bracket Dimensions .....           | page 8  |
| Fig. 4 Type II Electronic Cabinet Dimensions .....          | page 9  |
| Fig. 5 Type III Electronic Cabinet Dimensions .....         | page 10 |
| Fig. 6 Antenna Mounting Bracket Dimensions.....             | page 11 |
| Fig. 7 Pole Top Mounting Bracket .....                      | page 13 |
| Fig. 8 Electronic Cabinet Mounting (Side View).....         | page 14 |
| Fig. 9 Siren to Pole Top Mounting Bracket (Side View) ..... | page 17 |
| Fig. 10 Antenna Mounting Orientation .....                  | page 18 |
| Fig. 11 Solar Panel Wiring Connections.....                 | page 20 |
| Fig. 12 Solar Panel Mounting Views.....                     | page 21 |
| Fig. 13 Rotor Control and Siren Amplifier Connections ..... | page 24 |
| Fig. 14 AC Outlet Installation .....                        | page 26 |
| Fig. 15 Battery Connections (Type II Cabinet).....          | page 28 |
| Fig. 16 Battery Connections (Type III Cabinet) .....        | page 29 |
| Fig. 17 Landline Wiring.....                                | page 30 |
| Fig. 18 System LED Indicators .....                         | page 32 |
| Fig. 19 Electronic Cabinet Front Panel .....                | page 33 |

**Fig. 1: Sample Station Drawing (AC Powered Battery Charger)**



**Fig. 2: Sample Station Drawing (Optional Solar Powered Battery Charger)**



## **An Important Note to the Installation Technicians...**

The installation of this product requires careful planning and attention to detail! The installation of this system should **NOT** be attempted by individuals without experience in the disciplines necessary to this procedure (i.e. High-voltage electrical wiring, utility pole installation, etc.).

The installation of the WPS-4000 station provided in this manual follows a logical progression. This process is not arbitrary and was developed using information gathered from both the manufacturer and experienced field technicians. Deviations from any of these procedures are not recommended unless they are in contradiction with local codes. **IN ALL INSTANCES, LOCAL CODES TAKE PRECEDENT OVER PROCEDURES OUTLINED HEREIN.**

It is the responsibility of the installation technicians to read this entire manual. The installation procedure should not begin until all personnel are familiar with the entire process. The overall process includes the following:

### **Installation Sequence**

- 1. Site Selection**
- 2. Utility Pole Preparation**
- 3. Mount Pole Top Bracket and Ground Wire**
- 4. Mount Electronic Cabinet to Pole**
- 5. Mount Siren Assembly to Pole Top Bracket and Conduit to Pole**
- 6. Set Utility Pole (pointing speaker North)**
- 7. Prepare and Mount Antenna Assembly (if present)**
- 8. Prepare and Mount Solar Panels and Conduit (if present)**
- 9. Installation of AC or Solar Service and Batteries**
- 10. Confirm Proper System Operation**

## **Section I: Site Selection**

**The site selection for the WPS-4000 requires careful consideration in order to achieve the optimum coverage of the siren station. For a guideline to system planning, sound propagation and site selection we direct the user to the Federal Emergency Management Agency's "Outdoor Warning Systems Guide, CPG 1-17."**

**The Location of the siren site should be reviewed for its compatibility with its surroundings such as private homes, schools and hospitals. The user is cautioned to consider the use of hearing protection devices for service personnel working in close proximity to the speaker cluster.**

**Access to the siren site is important from the standpoint of service, maintenance inspection and access to a utility service connect.**

**Site locations for radio controlled units should be reviewed for radio reception.**

## **Section II: Utility Pole Preparation...**

### **a) Pole Selection**

**NOTE:** This installation manual will address the procedures applicable to wooden utility poles of specific size and dimensions. Procedures for poles consisting of other materials (steel, concrete, etc.) are not addressed within this document. The information presented, however, provides the necessary data and guidelines for a successful installation regardless of pole material.

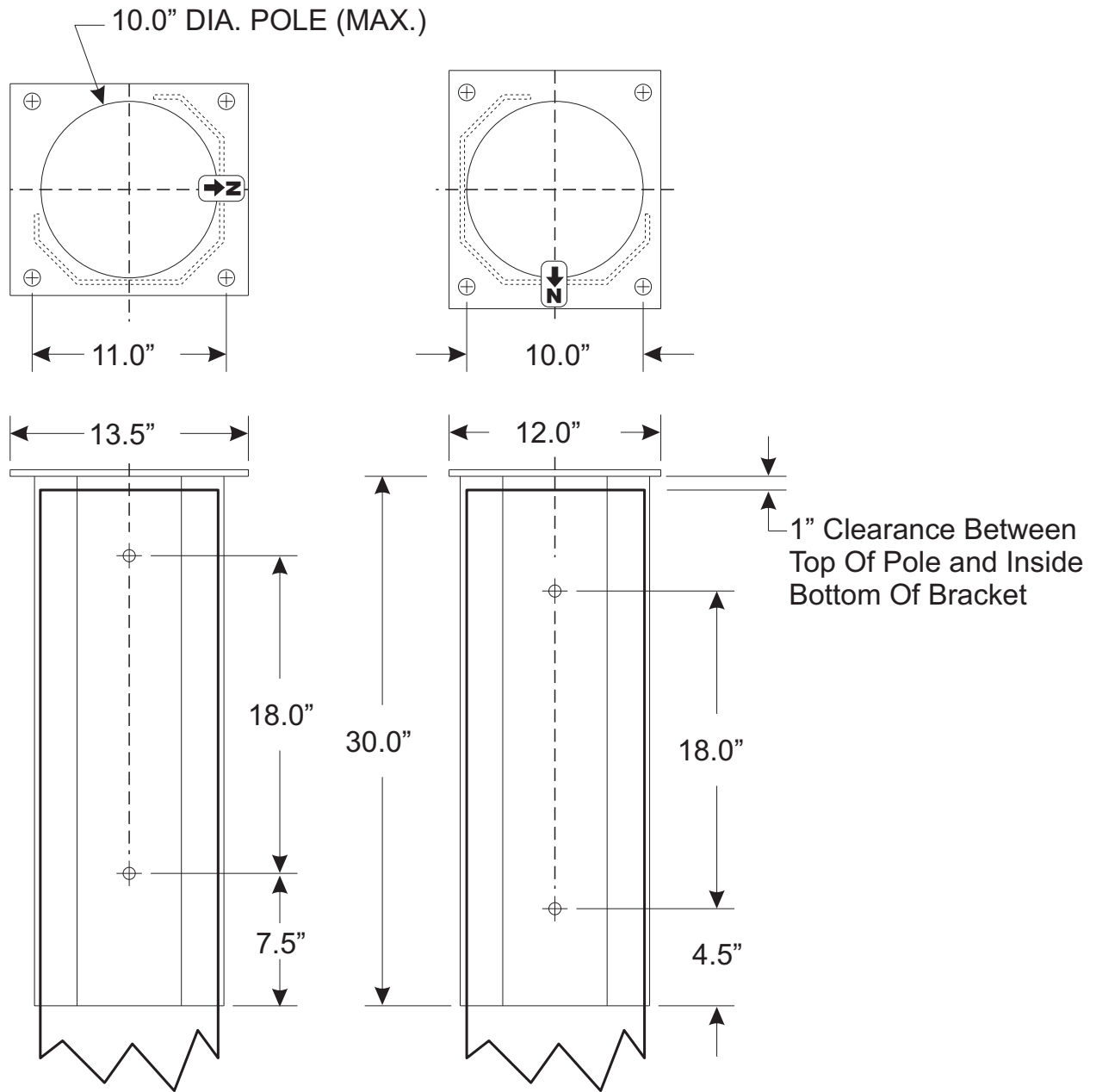
A WPS-4000-3 or WPS-4000-4 system may use a Class 2 or Class 1 utility pole. The WPS-4000-8 requires the use of a Class 1 utility pole. The length of the utility pole is consistent regardless of speaker cell quantity. The total length of the pole referenced within this document is 60 feet. The pole depth of the set pole is 10 feet, leaving a 50 foot pole as measured from the top of the pole to the ground. The utility pole should be set in accordance with local codes.

The inside area of the pole top mounting bracket will accept a pole that is no greater than 10.00" in diameter. On large scale projects, it is beneficial to order the pole to be "gained" to a top diameter of 9.5" +/- .50" for the top 30" section of the utility pole.

### **b) Component Dimensions**

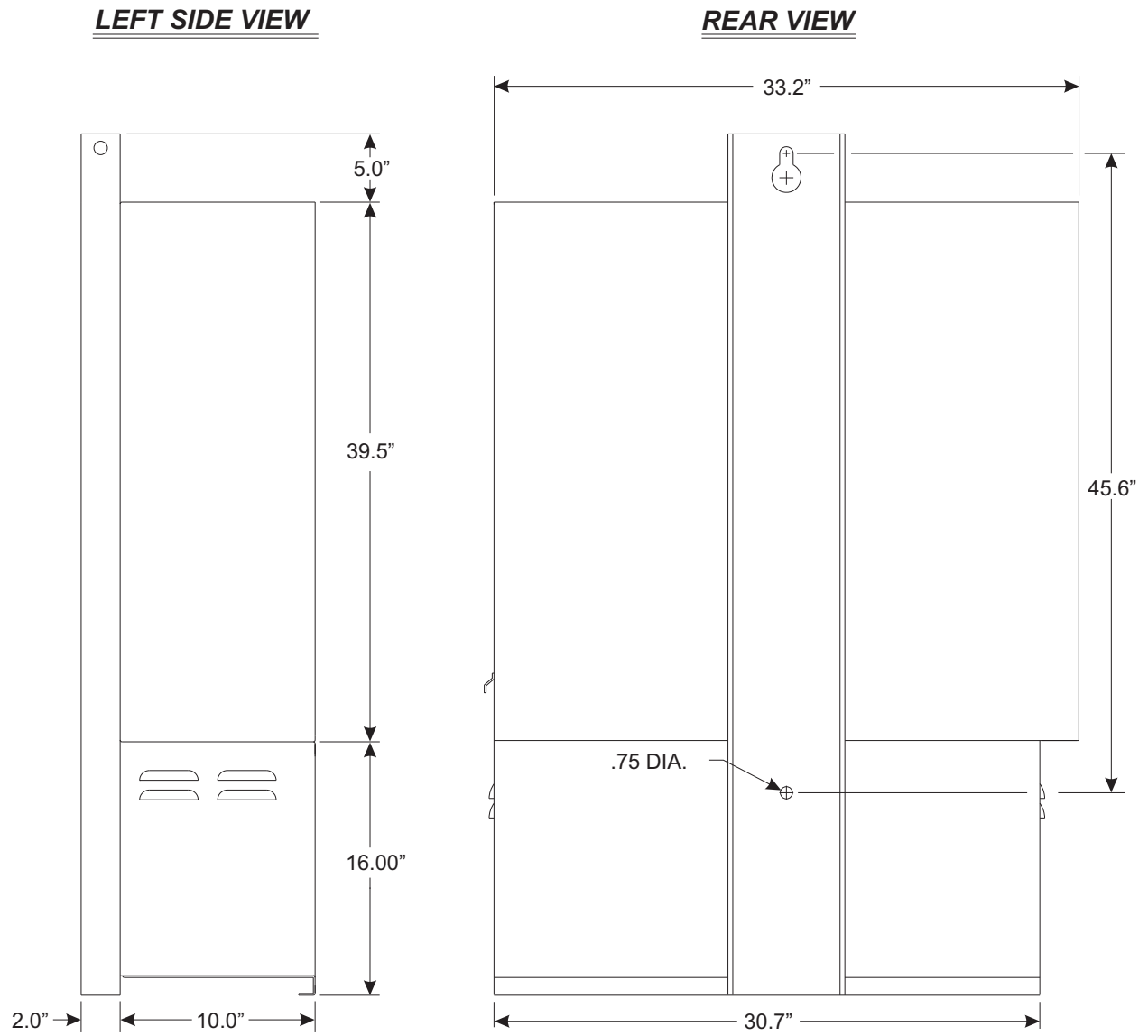
The utility pole may be pre-drilled prior to installation. The dimensions for all potentially mounted equipment are as follows:

**Fig. 3: Pole Top Mounting Bracket Dimensions**

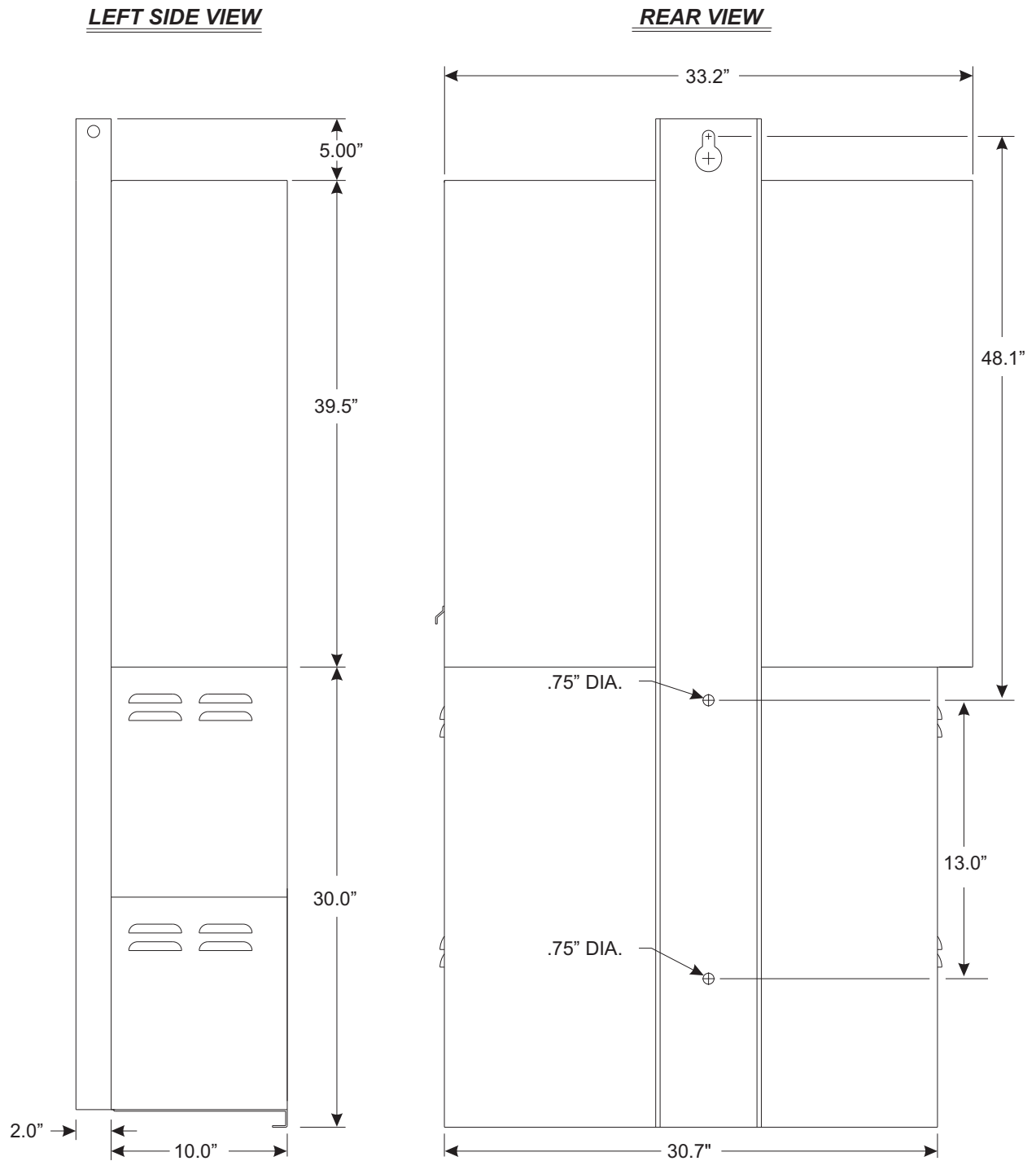




**Fig. 4: Type II Electronic Cabinet Dimensions**

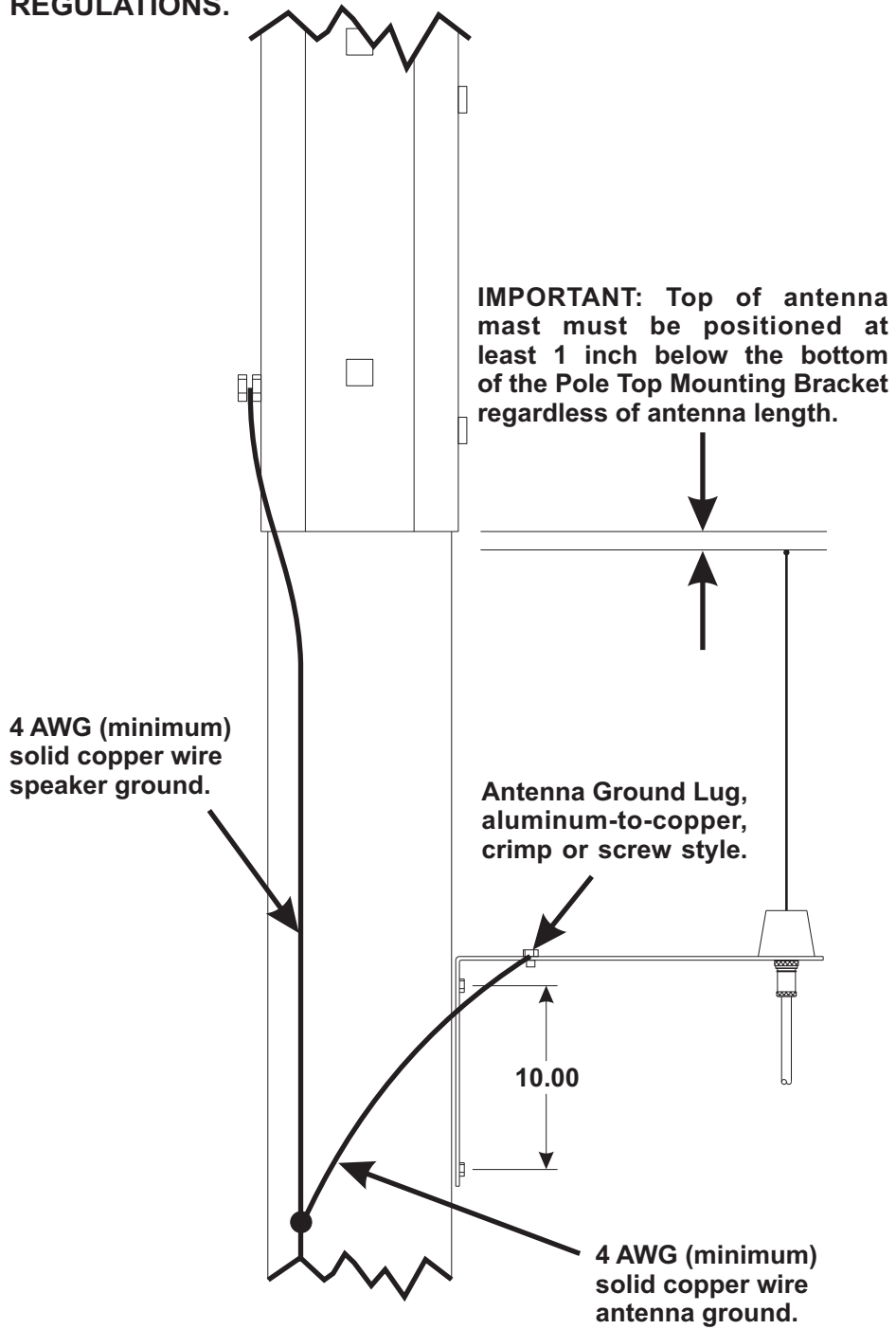


**Fig. 5: Type III Electronic Cabinet Dimensions**



**Fig. 6: Antenna Mounting Bracket Dimensions**

**NOTE: Antenna installation must be in compliance with all FCC REGULATIONS.**



## **Section III: Equipment Mounting**

### **a) Pole Top Bracket Installation...**

**Items Required for installation (not included)....**

- (4) 5/8" x 14" Hex or Square head mounting bolts**
- (4) 5/8" Hex or Square head nuts**
- (8) 5/8" Flat Washer sized for the above referenced mounting bolt**
- (4) 5/8" Lock Washer**

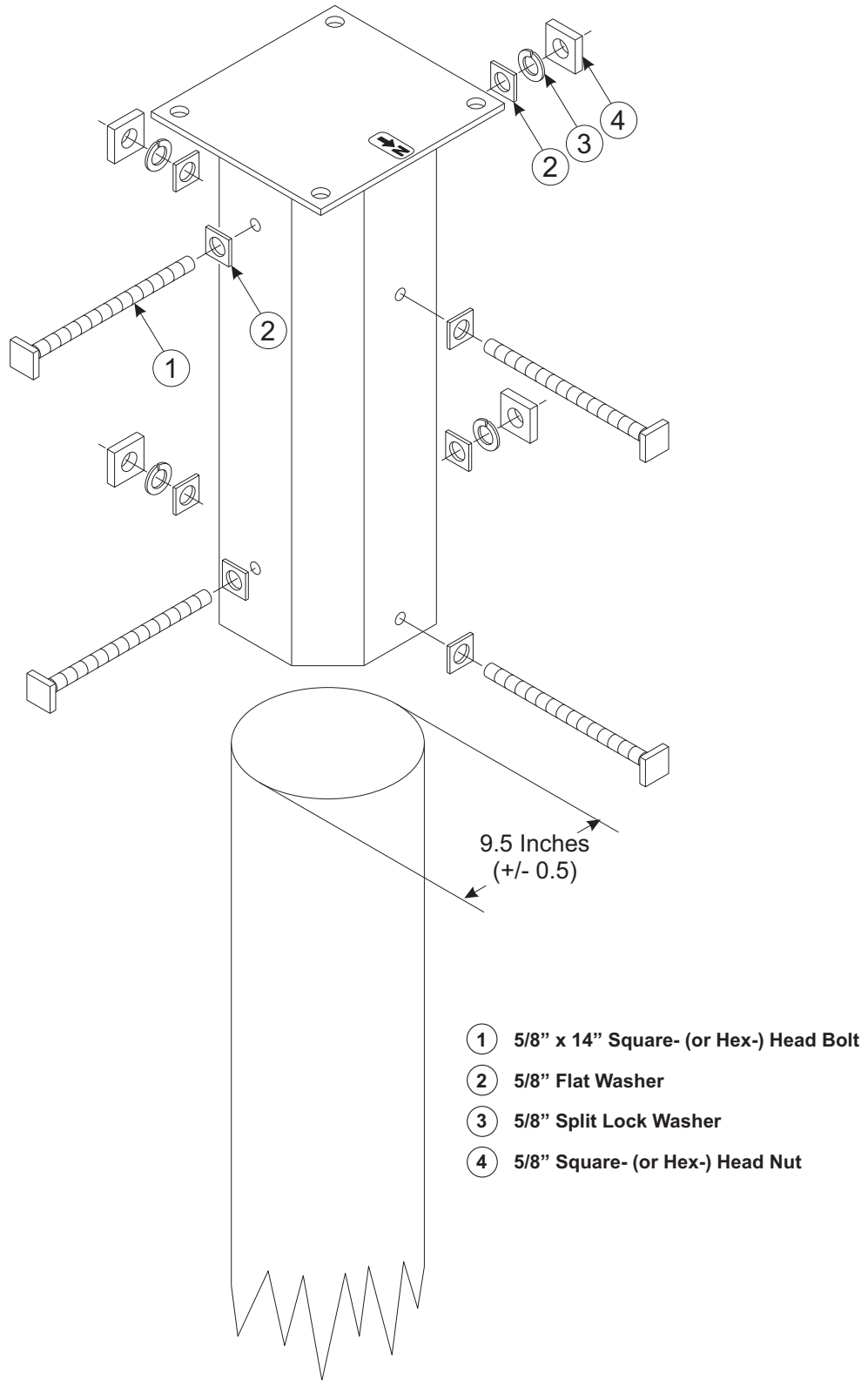
- 1. Position the WPS-4000 pole top mounting bracket onto the top of the pole (see "Fig. 7: Pole Top Mounting Bracket" on page 13). Make sure there is a 1 inch space between the top of the pole and the pole top mounting bracket(see "Fig. 8: Electronic Cabinet Mounting (Side View)" on page 14).**

**NOTE:** The inside area of the pole top mounting bracket will accept a pole that is no greater than 10.00" in diameter. On large scale projects, it is beneficial to order the pole to be "gained" to a top diameter of 9.5" +/- .50" for the top 30" section of the utility pole.

- 2. Using the pole top mounting bracket as a guide, drill four mounting holes through the pole at the bracket mounting hole locations. These holes should be sized to accommodate the above referenced hardware.**
- 3. Secure the bracket to the pole using the prescribed hardware (see "Fig. 7: Pole Top Mounting Bracket" on page 13). Be sure to position all the associated hardware items in their proper order.**
- 4. Secure a length of #4 solid copper wire to the pole top bracket grounding lug using the supplied nut. Make sure that this wire is of sufficient length to reach the ground when the pole has been set.**

**NOTE:** All Hardware used for connecting equipment to the utility pole should be inspected for tightness between 12 to 18 months after installation. Some shrinkage of the newly treated utility pole may occur, loosening connections.

**Fig. 7: Pole Top Mounting Bracket**



## **b) Electronic Cabinet Mounting and Siren Connections...**

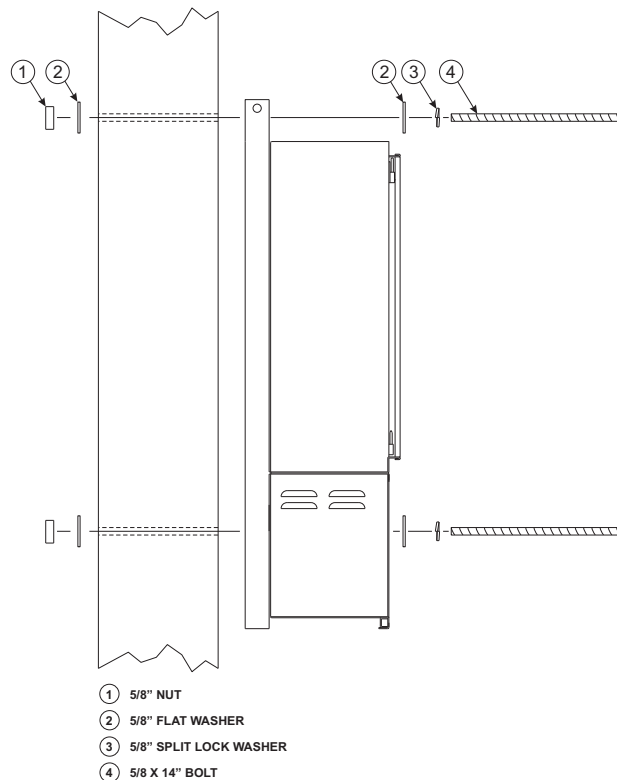
### **Mounting**

Items Required for installation (not included)....

For Type II & III cabinets

| <b>Qty.<br/>(Type II)</b> | <b>Qty.<br/>(Type III)</b> | <b>Description</b>  |
|---------------------------|----------------------------|---|
| (2)                       | (3)                        | <b>5/8" x 14" Hex or Square head mounting bolts</b>   |
| (4)                       | (6)                        | <b>5/8" Flat Washer sized for the above mounting bolt</b>   |
| (2)                       | (3)                        | <b>5/8" Split-Lock Washer</b>   |
| (2)                       | (3)                        | <b>5/8" Hex or Square head nuts</b>   |
| (1)                       | (1)                        | <b>Aluminum-to-Copper lug sized for #4 ground wire (crimp or screw style)</b>                           |
| (1)                       | (1)                        | <b>Stainless Steel 1/4-20 x 2" bolt with appropriately sized flat washer, split-lock washer and nut</b> |
| (1)                       | (1)                        | <b>10' Copper ground rod</b>  |

**Fig. 8: Electronic Cabinet Mounting (Side View)**



The WPS-4000 siren case assembly may be installed onto the pole and wired before setting the pole.

**NOTE:** Note: Due to the weight of the siren amplifier panel, the electronic cabinet assembly must be transported in an upright fashion to prevent distortion of the amplifier panel.

1. It is necessary for the installer to remember that two factors should determine the optimum mounting location; the desired distance of the mounted cabinet to the ground (typically 10 to 12 feet as measured from the bottom of the cabinet) and available speaker wire length (speaker assemblies are provided with a minimum of 50 feet of speaker wire as measured from the bottom of the speaker assembly).
2. After the mounting location has been determined, drill an appropriately sized thru-hole into the pole at the top cabinet mounting hole. Install a bolt loosely into the hole and hang the cabinet onto the bolt.
3. With the cabinet fitted snugly to the pole, mark the surface of the pole at the lower mounting hole location inside the battery storage compartment. Type III cabinets will have an additional mounting hole located in the second battery storage compartment (see “Fig. 5: Type III Electronic Cabinet Dimensions” on page 10). Remove the cabinet from the pole and drill an appropriately sized thru-hole into the pole at the location(s) marked. Return the cabinet to its mounting location and secure to the pole using the specified hardware.
4. Install an aluminum-to-copper lug (crimp or screw style) onto the #4 solid copper wire. Secure this to the cabinet mounting channel in hole supplied using stainless steel 1/4 - 20 hardware.
5. Install the ground rod as specified by local codes and connect both copper wires (from pole top mounting bracket and electronic cabinet) to this rod.
6. Install rigid steel conduit and necessary couplings from the speaker’s 1” conduit adapter to the 1” speaker conduit protruding from the base of the siren case assembly. The first section of conduit may be installed onto the speaker’s base casting prior to mounting the speaker to the pole top bracket. At the option of the user, conduit unions may be used between the first section of conduit and the speaker base casting and at the speaker cable conduit entrance to the siren case assembly.

**NOTE:** If the location of the conduit on the pole requires difficult conduit bends or couplings, a section of metal bonded seal tight conduit **NOT TO EXCEED 24 INCHES** may be used at the top of the pole and/or at the bottom of the pole as needed for the speaker cable installation.

Batteries for the system should not be installed until the siren station is set in place, otherwise some leakage of the battery fluid may occur. Batteries should not be connected to the system until AC power (or solar power if equipped) is available to the system to operate the system’s battery charger.

## **c) Siren Assembly Mounting...**

**Hardware required for installation (factory included)....**

- (8) 3/4" Hex Head nuts**
- (8) 7/8" Flat Washers**
- (4) 3/4" Split Lock Washers**

- 1. Mount the speaker/rotator assembly to the pole top bracket. Make sure that the "N" cast into the top of the rotor assembly is oriented to the "N" on the pole top bracket. Secure the rotor assembly to the bracket using the hardware provided.**
- 2. Sling or cradle the utility pole in a safe manner so that the pole top is 3 to 4 feet off the ground. This will allow the speaker assembly to clear the ground when installed.**
- 3. Locate the 4 mounting studs on the bottom of the speaker assembly (see "Fig. 9: Siren to Pole Top Mounting Bracket (Side View)" on page 17).**
- 4. Thread a 3/4" hex nut onto each of the mounting studs until there is approximately 1" of space between the top of the nuts and the bottom of the siren assembly. This space will allow the speaker assembly to be leveled once the pole has been set.**
- 5. Install a 7/8" flat washer onto each of the mounting studs.**
- 6. Insert the four mounting studs through the mounting holes on the top of the pole top bracket. The bottom of the siren assembly should lie flat against the pole top bracket.**
- 7. Install a 7/8" flat washer onto each of the mounting studs.**
- 8. Install a 3/4" split lock-washer onto each of the mounting studs.**
- 9. Thread a 3/4" hex nut onto each of the mounting studs. Tighten this nut firmly to secure the siren assembly to the pole top bracket.**

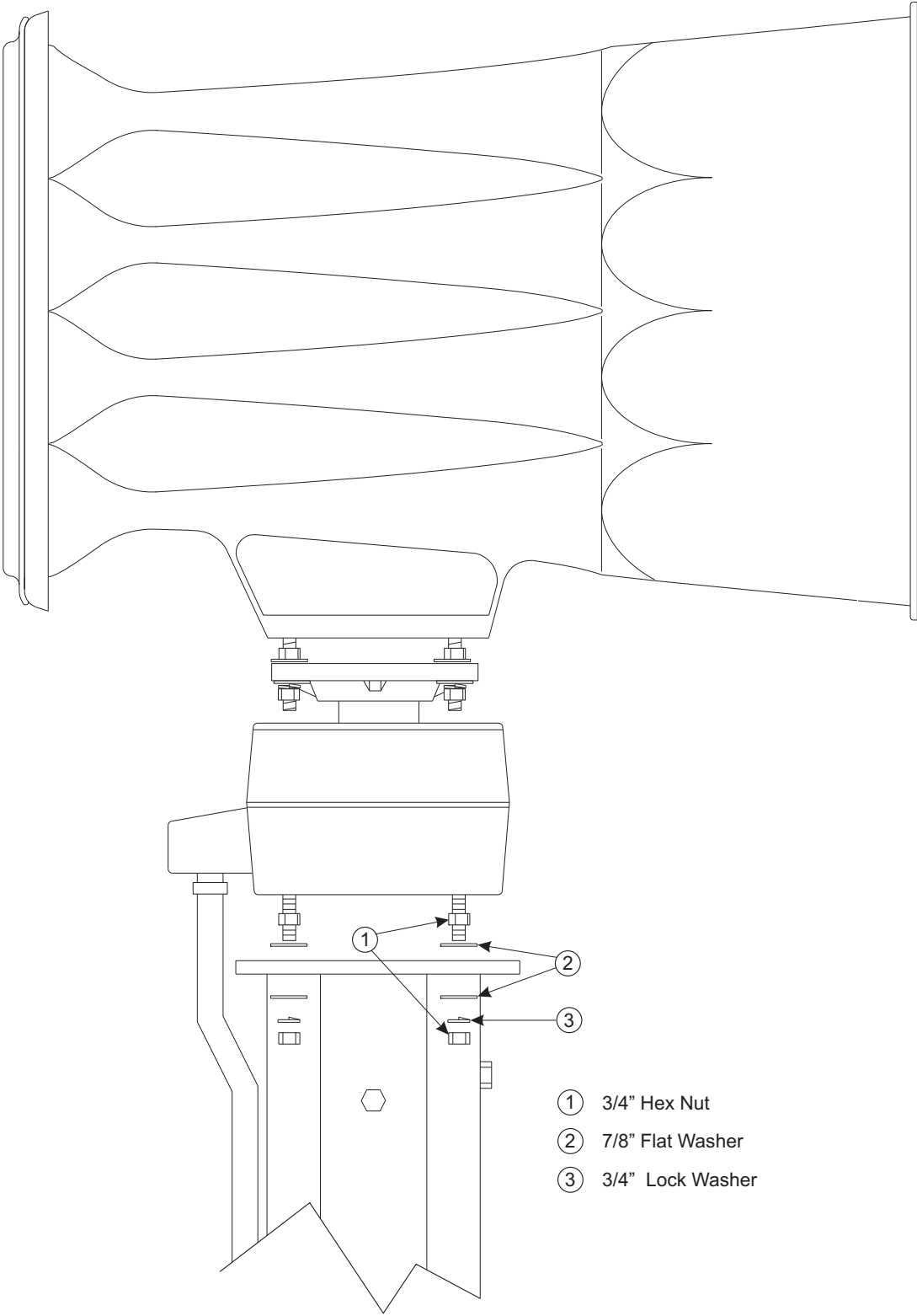
**At this point the pole may now be set. However, the installer may use their own discretion as to whether to mount the electronic cabinet onto the utility pole before the pole is set.**

**When setting the pole, make sure to rotate the pole so that the speakers are pointed North. THIS IS IMPORTANT!**

**When the pole has been set, use the adjustment nuts (indicated in step 2) to adjust the siren assembly until it is level.**



**Fig. 9: Siren to Pole Top Mounting Bracket (Side View)**



## **d) Antenna Mounting (optional)...**

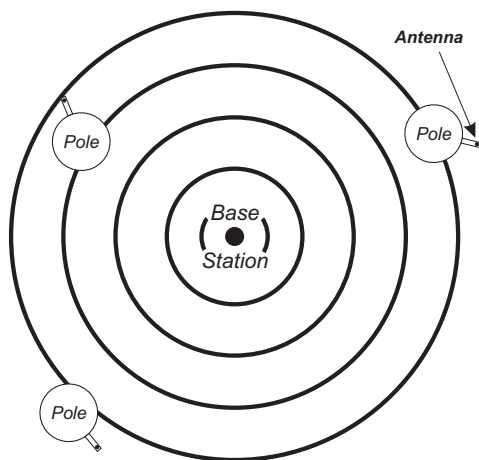
**NOTE:** Antenna installation must be in compliance with all FCC regulations.

The proper antenna bracket mounting location is determined by several considerations. The antenna bracket should be positioned as high on the utility pole as is possible. However, under no circumstances should the top of the installed antenna must be any closer than one inch from the bottom of the Pole Top Mounting Bracket (see “Fig. 6: Antenna Mounting Bracket Dimensions” on page 11). Be sure to ground the antenna bracket as shown using 4 AWG solid copper wire. The antenna cable provided by the factory is 35 feet in length.

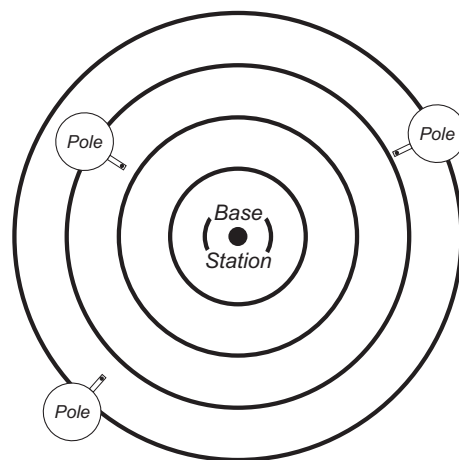
It is also important to remember that the antenna **MUST** be mounted on the side of the utility pole that faces the transmitter (see below)

**Fig. 10: Antenna Mounting Orientation**

### ***Improper Antenna Orientation***



### ***Correct Antenna Orientation***



Refer to the installation sheet included with your antenna kit for further information regarding cable connections and antenna trimming.

## **e) Solar Panel Mounting (optional)...**

**The solar panel must be installed so that it is directly facing the earth's equator with an unobstructed view. Failure to orient the solar panel in this way will result in significantly reduced charging effectiveness.**

**The most critical aspect of properly mounting the solar panel involves achieving the optimum tilt angle. The tilt angle is determined by the distance between the upper and lower mounting brackets, as shown.**

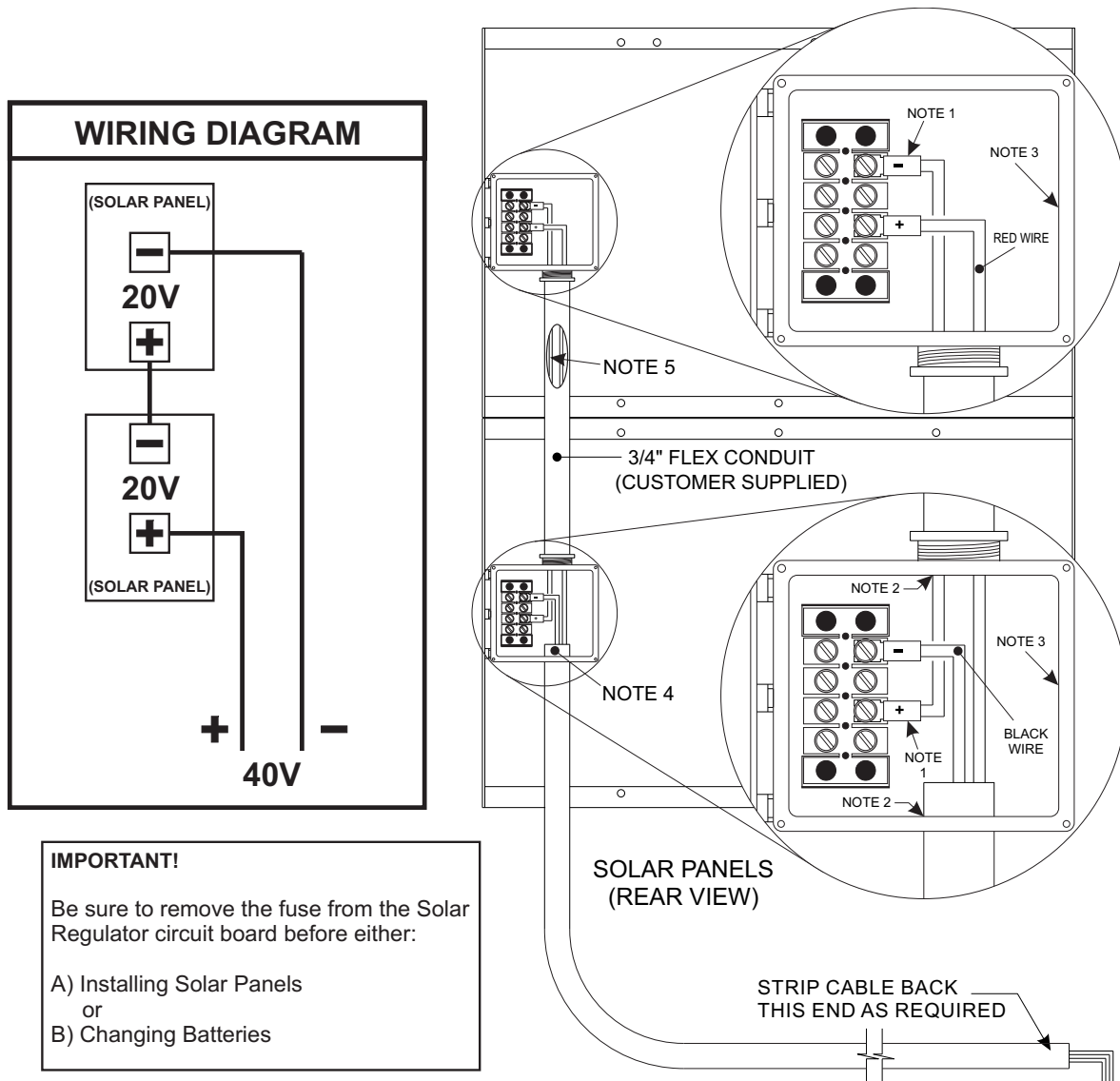
**Refer to page 20 for electrical connection information.**

**Refer to page 21 for general solar panel mounting.**

**Refer to page 22 for information on determining your specific mounting angle.**

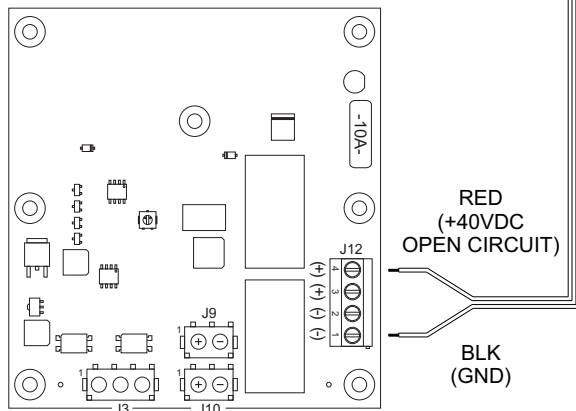
**Run rigid steel conduit from the solar panel to the 3/4" AC knockout located at the bottom of the siren case assembly. A section of up to 24 inches of metal bonded seal tight conduit may be utilized where conduit connections to the solar panel or electronic cabinet are not conveniently accomplished with rigid steel conduit and fittings. This conduit should be sealed to prevent insects and pests from entering the siren case assembly.**

**Fig. 11: Solar Panel Wiring Connections**

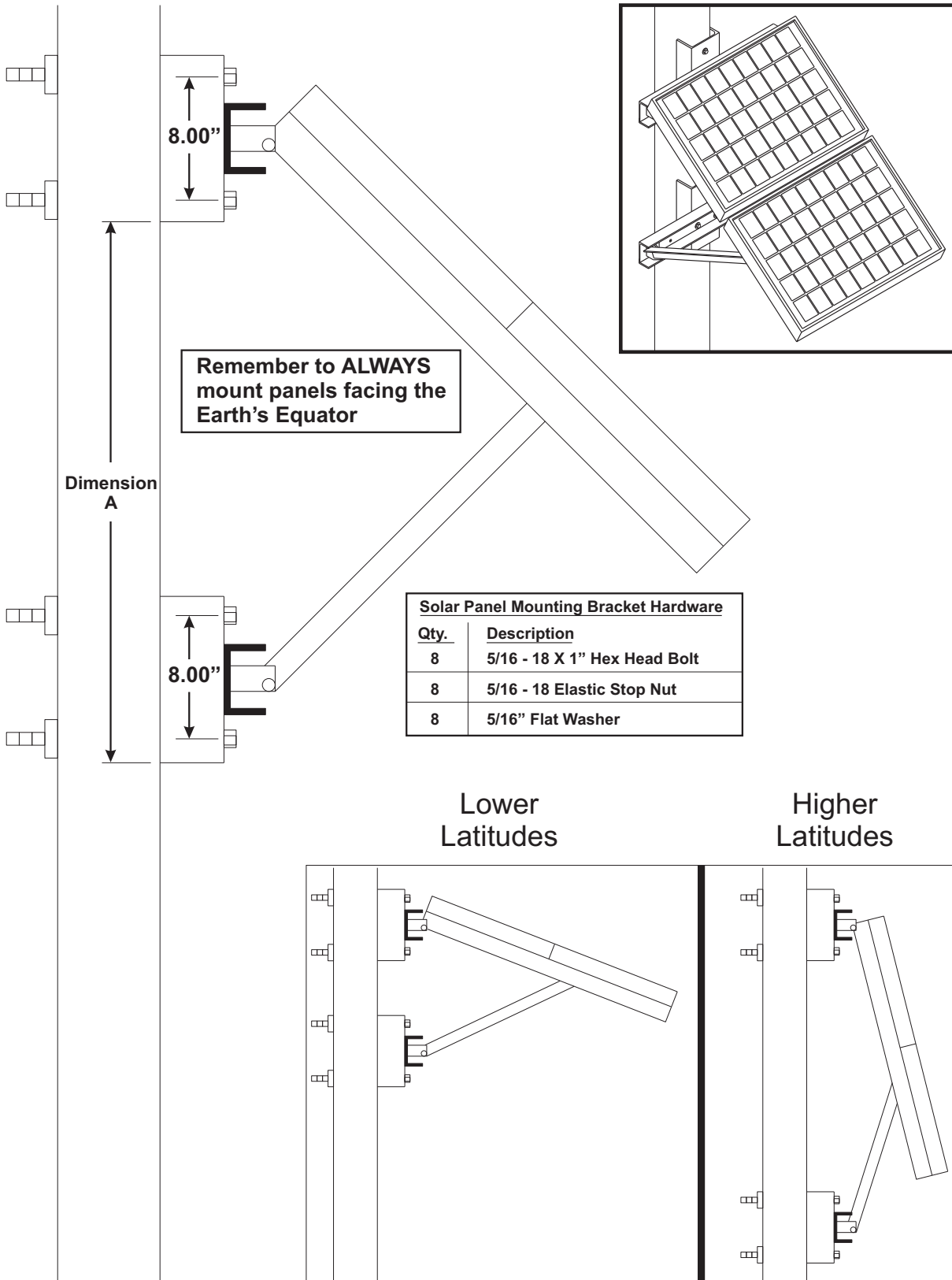


**NOTES:**

1. Always verify each solar panel's polarity with a volt meter before making any connections. The solar panels are to be wired together in series. Be sure to verify the solar panel specification of open circuit voltage measurement (approx. 20VDC). When properly wired together in series, the voltage measurement on the wires feeding the Solar Regulator will measure approx. 40VDC in open circuit.
2. Wire entrance hardware per local codes, water tight as required (3 places).
3. Electrical boxes shown with covers removed.
4. Cable to be stripped back 26" at solar panel end.
5. Supplied by Whelen, included with installation kit.



**Fig. 12: Solar Panel Mounting Views**



## f) Determining Solar Panel Mounting Angle

1. Determine the *LATITUDE* of your location.
2. Find your *Latitude* on the table below and not the corresponding *Tilt Angle*.

| <u>LATITUDE</u> | <u>TILT ANGLE</u>               |
|-----------------|---------------------------------|
| 0° to 9°        | 75° = Tilt Angle                |
| 10° to 20°      | 85° minus LATITUDE = Tilt Angle |
| 21° to 45°      | 80° minus LATITUDE = Tilt Angle |
| 46° to 65°      | 75° minus LATITUDE = Tilt Angle |
| 66° to 75°      | 10° minus LATITUDE = Tilt Angle |

3. Locate your TILT ANGLE in the list below. For every TILT ANGLE, there is a corresponding “Dimension A”. “Dimension A” represents the distance from the bottom of the upper mounting bracket to the bottom of the lower mounting bracket.

example 1:

Location LATITUDE is 30°

80° - 30° = 50° Tilt Angle

50° Tilt Angle = 33.60” Dimension A

example 2:

Location LATITUDE is 7°

7° = 75° Tilt Angle

75° Tilt Angle = 15.54” Dimension A

| Tilt Angle | Dimension A (inches) | Tilt Angle | Dimension A (inches) | Tilt Angle | Dimension A (inches) |
|------------|----------------------|------------|----------------------|------------|----------------------|
| 10         | 50.49                | 32         | 43.71                | 54         | 30.93                |
| 11         | 50.34                | 33         | 43.24                | 55         | 30.24                |
| 12         | 50.16                | 34         | 42.77                | 56         | 29.54                |
| 13         | 49.97                | 35         | 42.28                | 57         | 28.84                |
| 14         | 49.77                | 36         | 41.78                | 58         | 28.13                |
| 15         | 49.55                | 37         | 41.26                | 59         | 27.41                |
| 16         | 49.32                | 38         | 40.74                | 60         | 26.69                |
| 17         | 49.08                | 39         | 40.20                | 61         | 25.96                |
| 18         | 48.82                | 40         | 39.65                | 62         | 25.23                |
| 19         | 48.54                | 41         | 39.10                | 63         | 24.50                |
| 20         | 48.25                | 42         | 38.53                | 64         | 23.76                |
| 21         | 47.95                | 43         | 37.95                | 65         | 23.01                |
| 22         | 47.63                | 44         | 37.36                | 66         | 22.27                |
| 23         | 47.30                | 45         | 36.75                | 67         | 21.52                |
| 24         | 46.95                | 46         | 36.14                | 68         | 20.77                |
| 25         | 46.59                | 47         | 35.52                | 69         | 20.02                |
| 26         | 46.22                | 48         | 34.89                | 70         | 19.27                |
| 27         | 45.83                | 49         | 34.25                | 71         | 18.52                |
| 28         | 45.43                | 50         | 33.60                | 72         | 17.77                |
| 29         | 45.02                | 51         | 32.95                | 73         | 17.02                |
| 30         | 44.60                | 52         | 32.28                | 74         | 16.28                |
| 31         | 44.16                | 53         | 31.61                | 75         | 15.54                |

## Section IV: Wiring

### a) Siren Connections

For WPS-4000-3 & WPS-4000-4 systems, a 5-pair harness cable is provided. This cable has 5 BLACK wires numbered 1 to 5 and 5 RED wires numbered 1 to 5. WPS-4000-8 systems use a 10-pair harness cable 10 BLACK wires numbered 1 to 10 and 10 RED wires numbered 1 to 10. Also included with all WPS-4000 systems is a 12 conductor Rotor Control harness cable. This cable is routed from the rotor to the siren cabinet. Refer to the table below for the necessary wiring connections.

Unused wires should be dressed so they are out of the way. Do not cut these wires, as they can be used to replace damaged wires in the future.

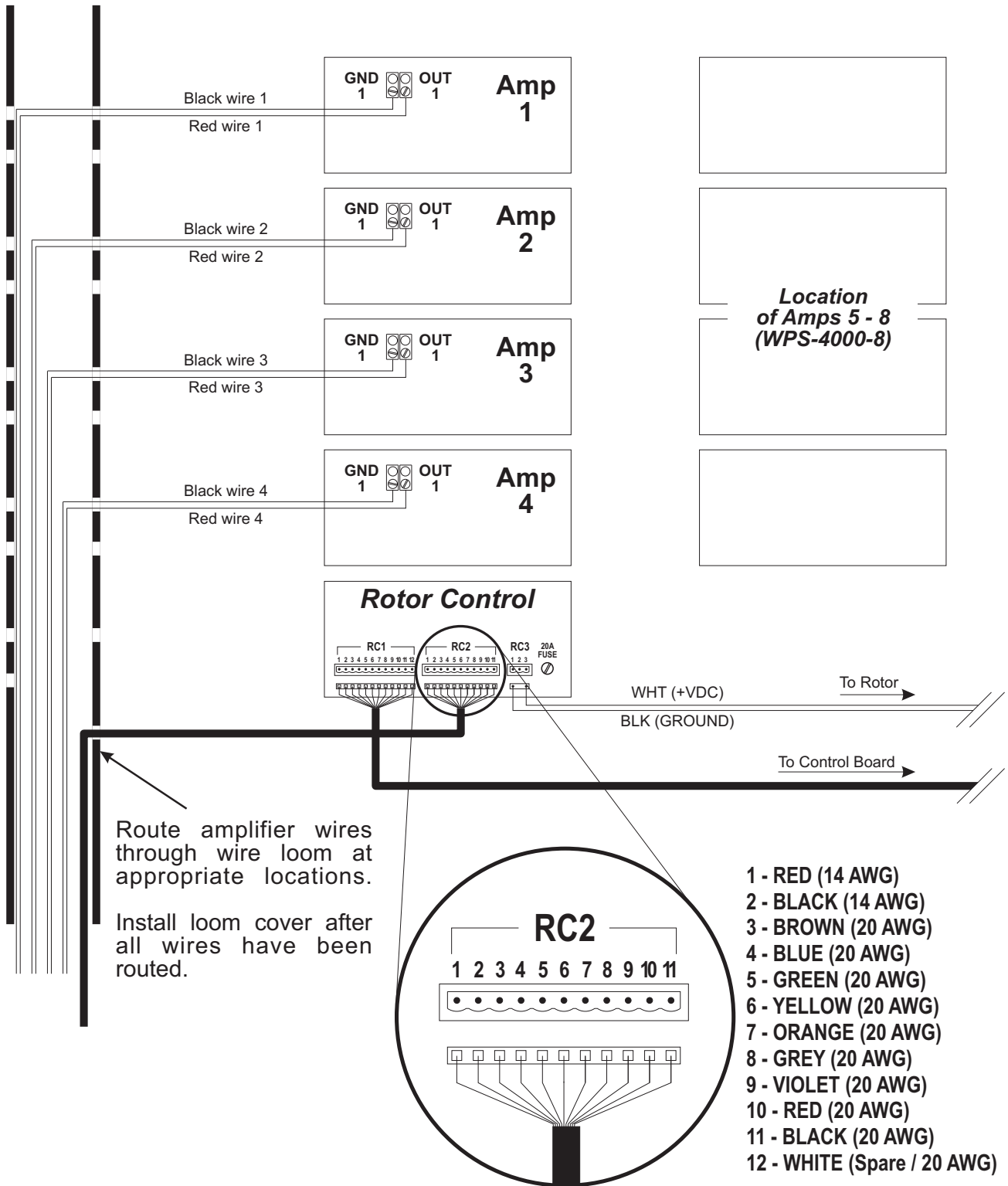
**NOTE:** The following procedure provides the information necessary for successfully connecting the siren harness wires to their designated amplifiers. Depending upon the distance between the siren base and the electronic cabinet, there will be varying lengths of wire remaining in the cabinet. It is the installers responsibility to properly trim and dress these wires in a fashion that not only leaves the wires organized, but also includes a service loop of suitable length. WPS-4000-8 harness cables may need their outer jackets stripped to allow the wires to fit through the flex conduit and into the siren cabinet.

1. Locate the siren wiring harness where it enters the electronic cabinet.
2. Locate the BLACK and RED wires marked 1 on their insulation. These wires are designated for connection to siren amplifier 1.
3. Route these wires through the cabinet's wire loom and connect to Amp 1 (see "Fig. 13: Rotor Control and Siren Amplifier Connections" on page 24).
4. Repeat steps 2 and 3, substituting the appropriate number for all remaining amps.
5. When all amplifiers have been wired, install loom cover.
6. Route rotor cable through the wire loom to the rotor control.
7. Locate the 11-position Phoenix connector included with your system. Insert the rotor control wires into this connector as follows:

| <u>Position</u> | <u>Color</u>    | <u>Position</u> | <u>Color</u>         |
|-----------------|-----------------|-----------------|----------------------|
| 1               | RED (14 AWG)    | 7               | ORANGE (20 AWG)      |
| 2               | BLACK (14 AWG)  | 8               | GREY (20 AWG)        |
| 3               | BROWN (20 AWG)  | 9               | VIOLET (20 AWG)      |
| 4               | BLUE (20 AWG)   | 10              | RED (20 AWG)         |
| 5               | GREEN (20 AWG)  | 11              | BLACK (20 AWG)       |
| 6               | YELLOW (20 AWG) | 12              | WHITE (Spare/20 AWG) |

8. Insert this connector into the receptacle marked "RC2" on the rotor control.

**Fig. 13: Rotor Control and Siren Amplifier Connections**





## **b) AC Wiring**

An AC Service (Single Phase only) with an acceptable disconnect is required. A 15 amp (minimum) 120 VAC circuit is recommended.

Locate the service on the pole according to local codes, taking care that the service entrance will meet height requirements once the pole is set into place.

The WPS-4000 includes a 15 amp, 120 VAC outlet. The cabinet's battery charger plugs into one of the receptacles. The remaining receptacle is available for use by service personnel (see "Fig. 14: AC Outlet Installation" on page 26).

**NOTE:** A section of up to 24 inches of metal bonded seal tight conduit may be utilized where conduit connections to the siren case assembly are not conveniently accomplished with rigid steel conduit and fittings.

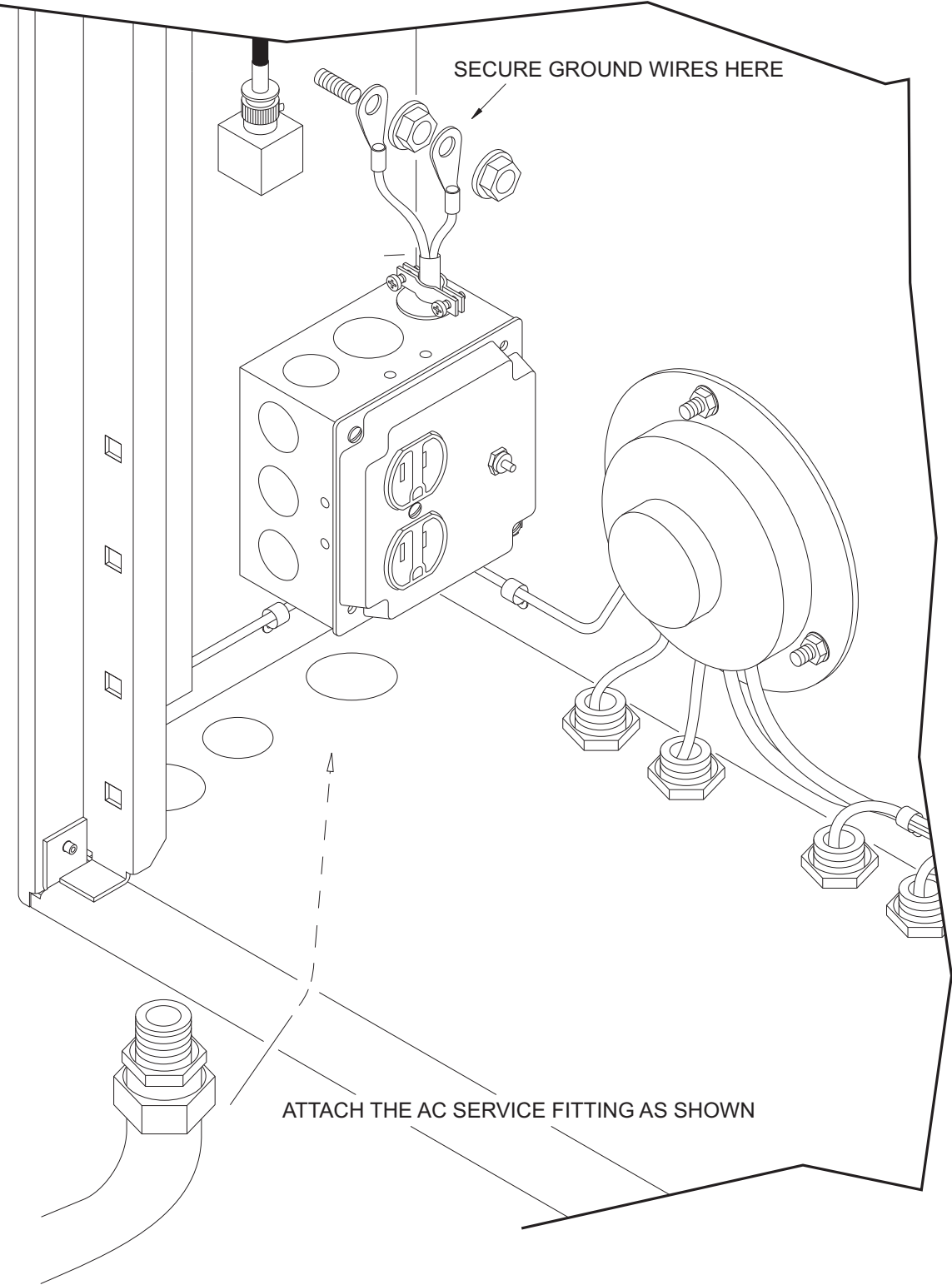
Each WPS-4000 siren system is supplied with a lightning arrestor which is to be installed on the AC service. Local codes should be reviewed and followed to establish the connection of this device on the primary or secondary side of the disconnect.

**NOTE:** The location of the siren site should be reviewed for the quality of the AC service. AC power sources that are subject to excessive power surges or transients are not acceptable.

The AC charger is simply plugged into an AC duplex outlet (factory included) installed as follows:

1. Remove the cover from the 4" x 4" box.
2. Position the 3/4" knock-out in the box above the 3/4" knockout in the cabinet.
3. Attach a flex fitting (not included) through the cabinet and the box. This will secure the box to the cabinet.
4. Connect the AC service to the leads on the cover assembly.
5. Attach the cover to the box.
6. Attach ground wire (GREEN) to cabinet ground stud above the installed outlet.

**Fig. 14: AC Outlet Installation**



## **c) Batteries**

1. **Make sure that the system battery switch is in the OFF position.**
2. **Install the batteries included with your system and connect them as shown in the illustration representing your cabinet type. MAKE SURE TO OBSERVE THE POLARITY OF THE TERMINALS BEFORE MAKING ANY CONNECTIONS.**

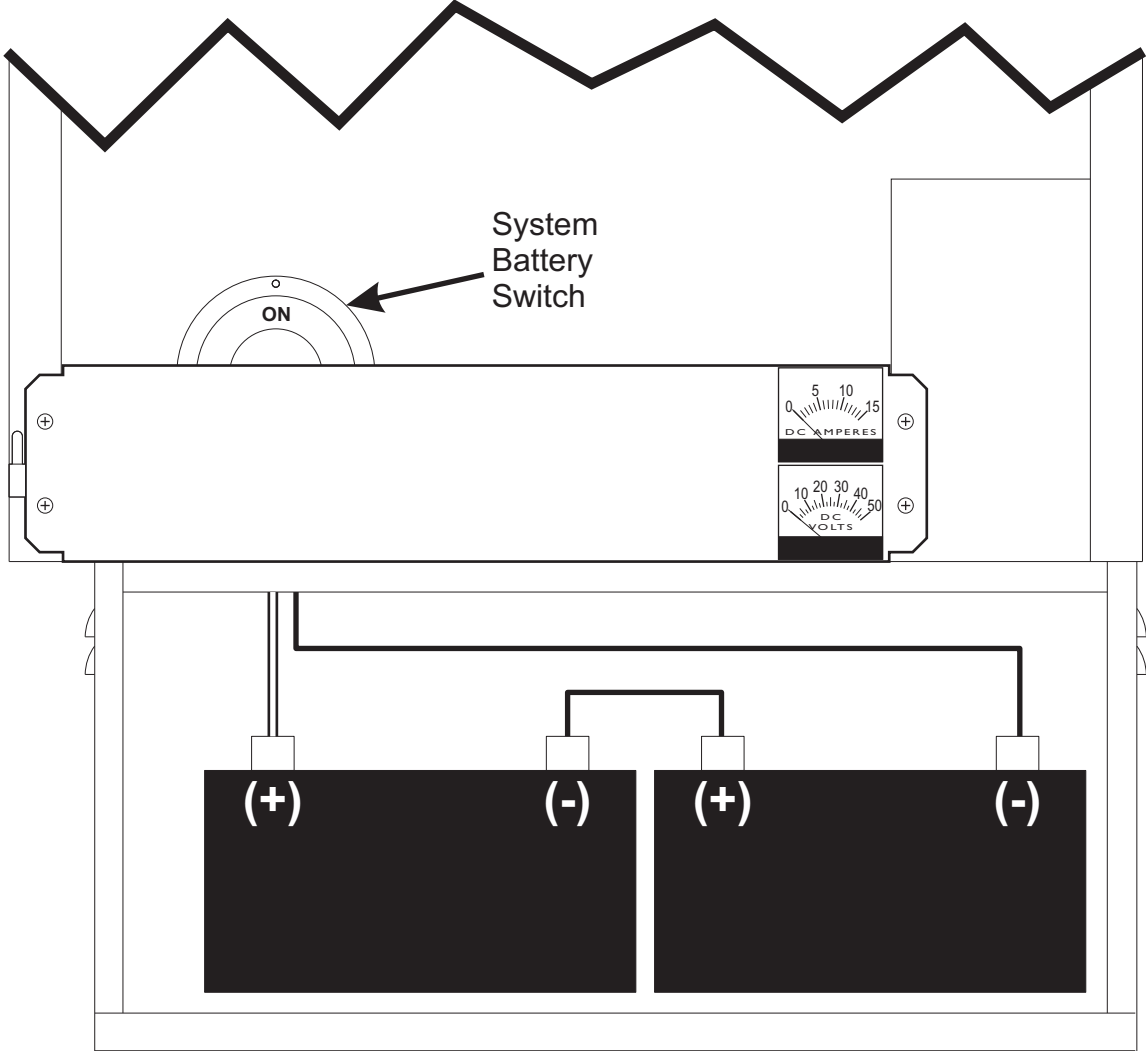
**NOTE:** For battery wiring, DC wiring conventions are used (BLACK is ground (-)).

*For Type II Cabinets (see “Fig. 15: Battery Connections (Type II Cabinet)” on page 28)*

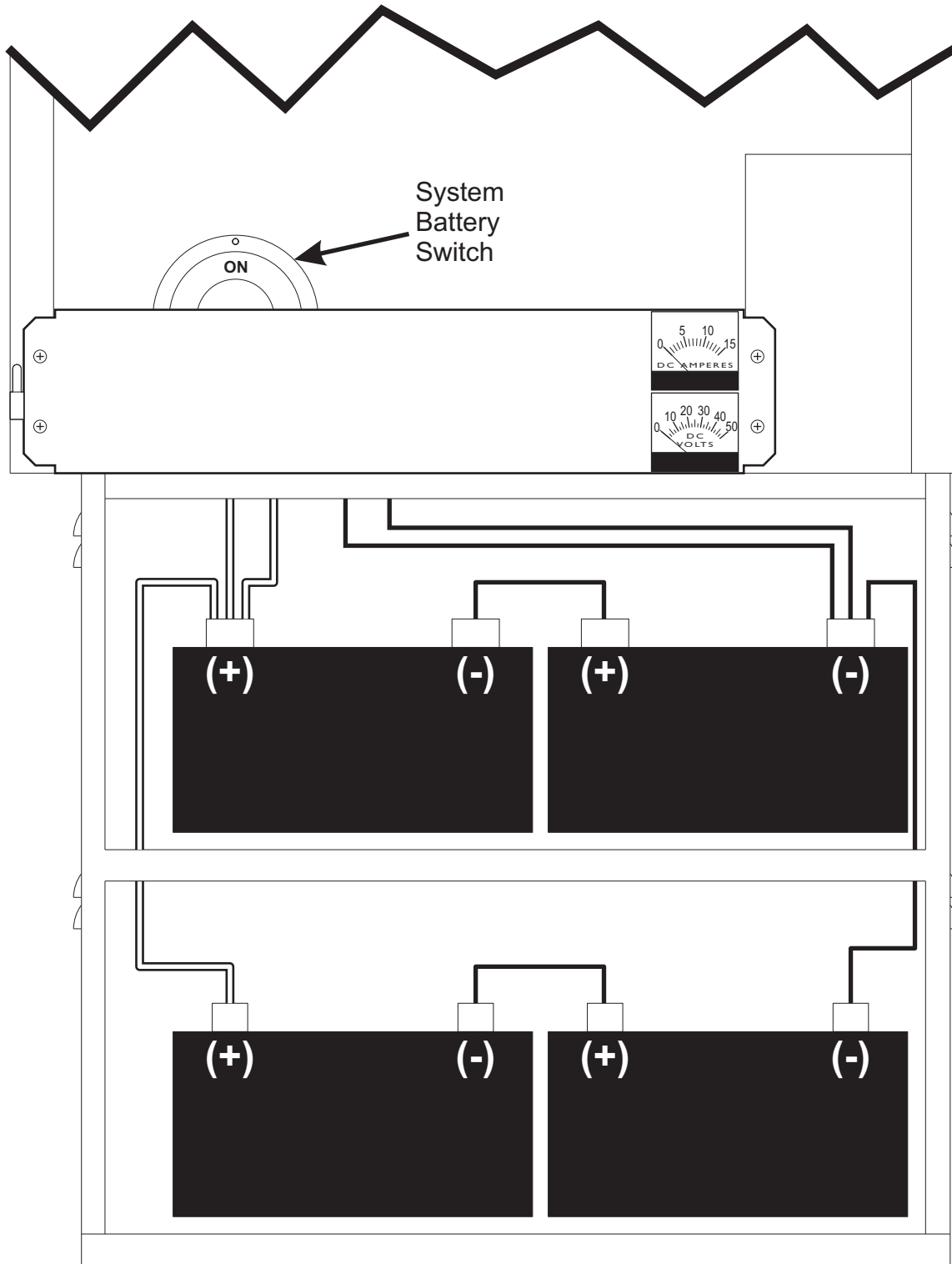
*Type III Cabinets (see “Fig. 16: Battery Connections (Type III Cabinet)” on page 29)*

3. **Rotate the system battery switch to the ON position.**
4. **Plug the battery charger into the AC outlet.**
5. **Verify system operation as outlined in the system maintenance check list.**

**Fig. 15: Battery Connections (Type II Cabinet)**



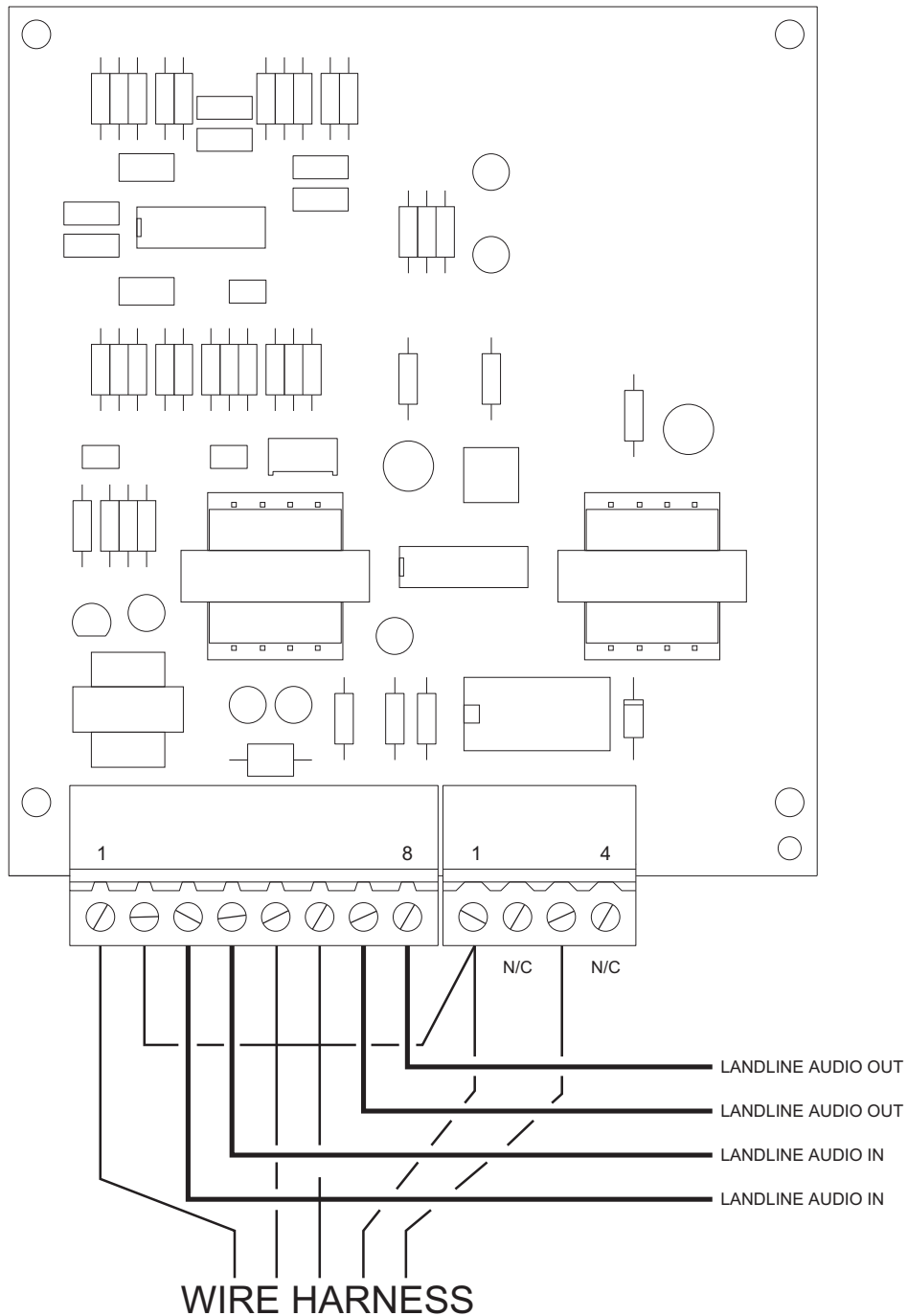
**Fig. 16: Battery Connections (Type III Cabinet)**



## **d) Landline (optional)**

As an option, the WPS-4000 may be remotely controlled by either landline or RF link. Either method communicates via a DTMF protocol. Remote control may be one-way or two-way. The one-way option simply controls the WPS-4000, while the two-way option controls the WPS-4000 and reports WPS-4000 status back to a central control point.

**Fig. 17: Landline Wiring**



## Section V: System Test...

After the installation of the WPS-4000 station has been completed, a basic system check is recommended to confirm that the system is functioning properly. Before initiating these tests, locate the system LED's on the main control board mounted to the cabinet door (see "Fig. 18: System LED Diagnostic Indicators" on page 32).

**NOTE:** The KEYPAD ARM button enables local station operation via keypad. Once pressed, the keypad remains active until either a) another keypad button is pressed, or b) 60 seconds have elapsed, whichever comes first. The KEYPAD ARM button must be pressed each time a keypad button is to be pressed. Note that the CANCEL button is always enabled and does not require Keypad Arm to be pressed.

1. Confirm that the ACTIVE light on the control board is flashing at a rate of a 1/2 second on and a 1/2 second off.
2. Press KEYPAD ARM, then the SI TEST® button on the siren front panel and check to make sure that all the siren amplifier diagnostic LED's illuminate for 5 seconds. These LED's are located on the front of the cabinet door. Also verify that the speaker rotated during the test.
3. After the amplifier LED's turn off, check to see if the AC, DC, PARTIAL, FULL and ROTOR LED's are on.

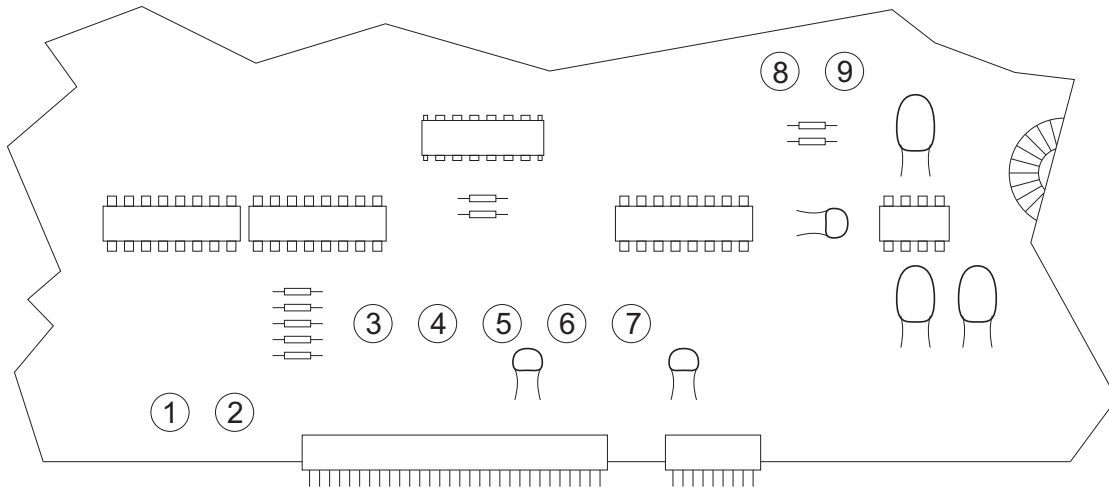
If one of your amplifier lights did not illuminate during this test then refer to the procedure below to troubleshoot the problem.

This procedure may be used when the Partial or Full LED's indicate a failure.

**NOTE:** In order for a "Full" indication to be valid, the "Partial" LED must also be on.

1. Press KEYPAD ARM, then the SI TEST® button located on the front panel of the electronic cabinet. Each amplifier has a red LED diagnostic indicator that is visible on the front panel (see "Fig. 19: Electronic Cabinet Front Panel (Type II)." on page 33).
2. A SI TEST® will cause each amplifier's diagnostic indicator to turn on. If one or more do not turn on, proceed to step 3. If all indicators turn on, the siren amplifiers are functioning properly.
3. Open the front panel and remove the speaker driver from the amplifier that did not light and install it onto an amplifier that did light. For example: If amplifier 1 did not light but amplifier 2 did, install speaker 1 on amplifier 2 and speaker 2 on amplifier 1. This will indicate if the failure was with the speaker or the amplifier. For more information on troubleshooting the system, refer to the advanced trouble shooting manual.

**Fig. 18: System LED Diagnostic Indicators**



- |  |   |
|--|---|
| <p>① Fault (RED) - Normally off. When a problem has been detected, this LED will be on.</p> <p>② Active - This LED normally flashes at a rate of once every half seconds. When a problem has been detected, this LED will stop flashing or be off. Also indicates receipt of DTMF data by flashing at a faster rate for about 1 second.</p> <p>③ Rotator - This LED will light during siren activation if the rotor oscillates properly.</p> <p>④ Full - Normally on. If a siren amplifier does not operate properly during a tone activation or SI TEST®, this LED will be off.</p> <p>⑤ Partial - Normally on. If all siren amplifiers do not operate properly during a tone activation or SI TEST®, this LED will be off. If at least one amplifier operates properly, it will remain on.</p> | <p>⑥ DC - Normally on. If no DC voltage was detected during a siren tone or SI TEST®, this LED will be off.</p> <p>⑦ AC - Normally on. If no DC voltage was detected during a siren tone or SI TEST®, this LED will be off.</p> <p>⑧ Squelch - Normally off. This LED will light when the station is receiving a radio broadcast. If equipped with the optional receive tone/squelch tone, the LED will only light when the receive frequency and sub-audible tone squelch frequency tone is detected.</p> <p>⑨ PTT - Normally off. This LED will light when the station transmitter is active.</p> |
|--|---|

**NOTE: In some instances, optional circuit boards may be located directly above these LED's.**



**Fig. 19: Electronic Cabinet Front Panel (Type II).**

Siren Amplifier  
Diagnostic LED's  
(8 cell system shown  
for reference)

