

WHELEN[®]

ENGINEERING COMPANY INC.

51 Winthrop Road

Chester, Connecticut 06412-0684

Phone: (860) 526-9504

Internet: www.whelen.com

Sales e-mail: autosale@whelen.com

Customer Service e-mail: custserv@whelen.com

⚠ WARNING: This product can expose you to chemicals including Lead which is known to the State of California to cause cancer and birth defects or other reproductive harm. For more information go to www.P65Warnings.ca.gov.

WPS-2900 SERIES HIGH POWER VOICE & SIREN SYSTEM

INSTALLATION MANUAL

Mass Notification

Table Of Contents

Important Note To Installation Technicians	page 6
Section I: Site Selection	page 8
Section II: Utility Pole Preparation	
a) Pole Selection.....	page 9
b) Component Dimensions	page 9
Section III: Equipment Mounting	
a) Pole Top Mounting Bracket	page 14
b) Electronic Cabinet Mounting	page 16
c) Siren Assembly Mounting (5 or less speaker cells)	page 18
d) Siren Assembly Mounting (6 or more speaker cells)	page 19
e) Antenna Mounting (optional).....	page 21
f) Solar Panel Mounting (optional).....	page 22
g) Determining Solar Panel Mounting Angle	page 25
Section IV: Wiring	
a) Siren Connections	page 26
b) AC Wiring	page 28
c) Batteries	page 30
d) Landline.....	page 33
e) Auxiliary Control/Status	page 34
f) Paging Interface.....	page 38
g) Strobe Control Options STCTRL & SCWPS	page 39
h) Auxiliary Input Board.....	page 40
Section V: System Test.....	page 42

Illustrations

Fig. 1	Station Drawing.....	page 4
Fig. 2	Station Drawing (with optional Solar Panel).....	page 5
Fig. 3	Pole Top Mounting Bracket Dimensions.....	page 10
Fig. 4	Type II Electronic Cabinet Dimensions.....	page 11
Fig. 5	Type III Electronic Cabinet Dimensions.....	page 12
Fig. 6	Antenna Mounting Bracket Dimensions.....	page 13
Fig. 7	Pole Top Mounting Bracket.....	page 15
Fig. 8	Electronic Cabinet Mounting (Side View).....	page 16
Fig. 9	Siren to Pole Top Mounting Bracket (Side View).....	page 20
Fig. 10	Antenna Mounting Orientation.....	page 21
Fig. 11	Solar Panel Wiring Connections.....	page 23
Fig. 12	Solar Panel Mounting Views.....	page 24
Fig. 13	Siren Amplifier Connections.....	page 27
Fig. 14	AC Outlet Installation.....	page 29
Fig. 15	Battery Connections (Type II Cabinet).....	page 31
Fig. 16	Battery Connections (Type III Cabinet).....	page 32
Fig. 17	Landline Wiring.....	page 33
Fig. 18	Auxiliary Control/Status Board Wiring.....	page 36
Fig. 19	Auxiliary Control/Status Board Potentiometer Locations.....	page 37
Fig. 20	Paging Interface Board.....	page 38
Fig. 21	Strobe Control Board.....	page 39
Fig. 22	Auxiliary Input Board.....	page 40
Fig. 23	System LED Indicators.....	page 43
Fig. 24	Electronic Cabinet Front Panel.....	page 44

Fig. 1: Sample Station Drawing (AC Powered Battery Charger)

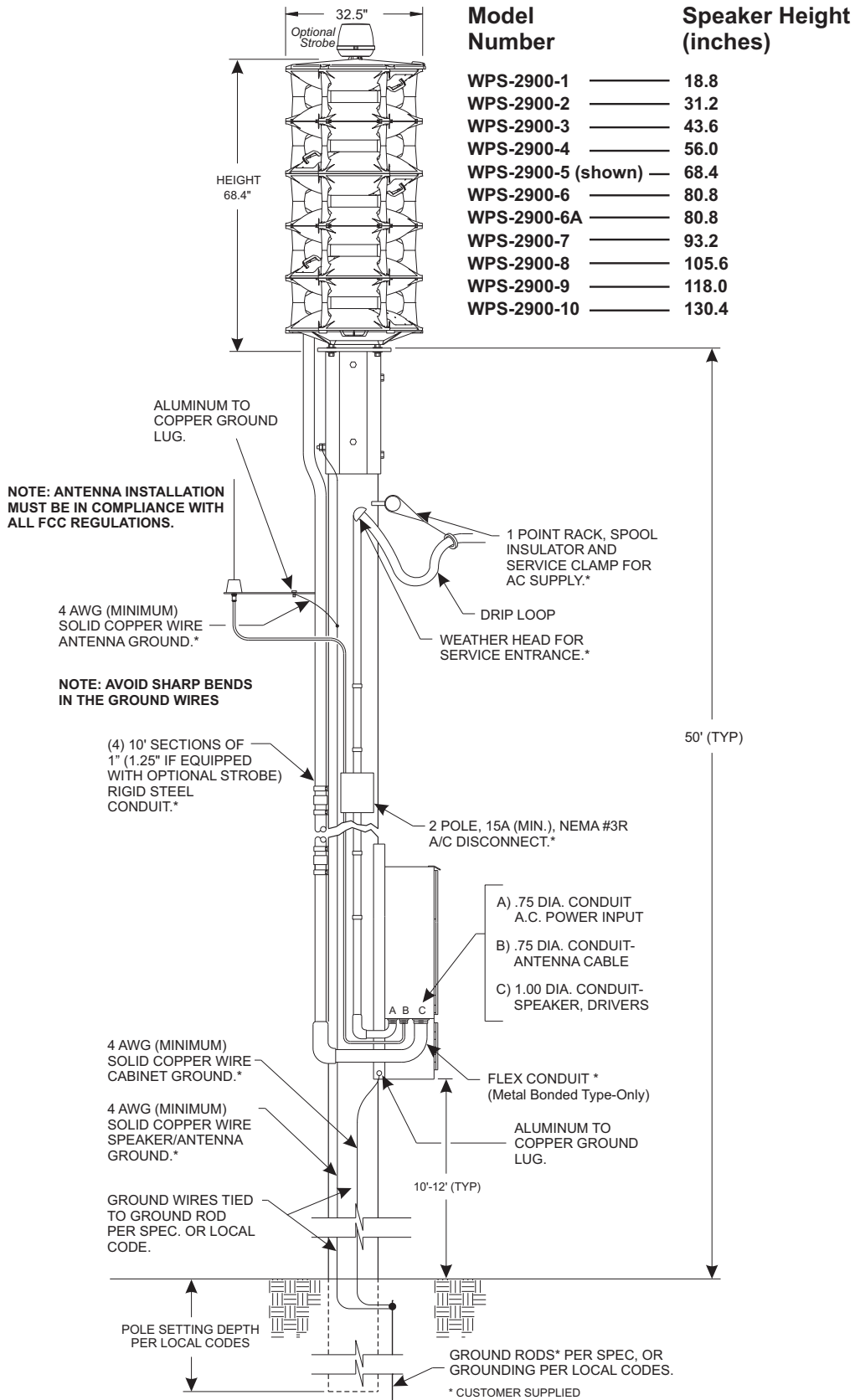
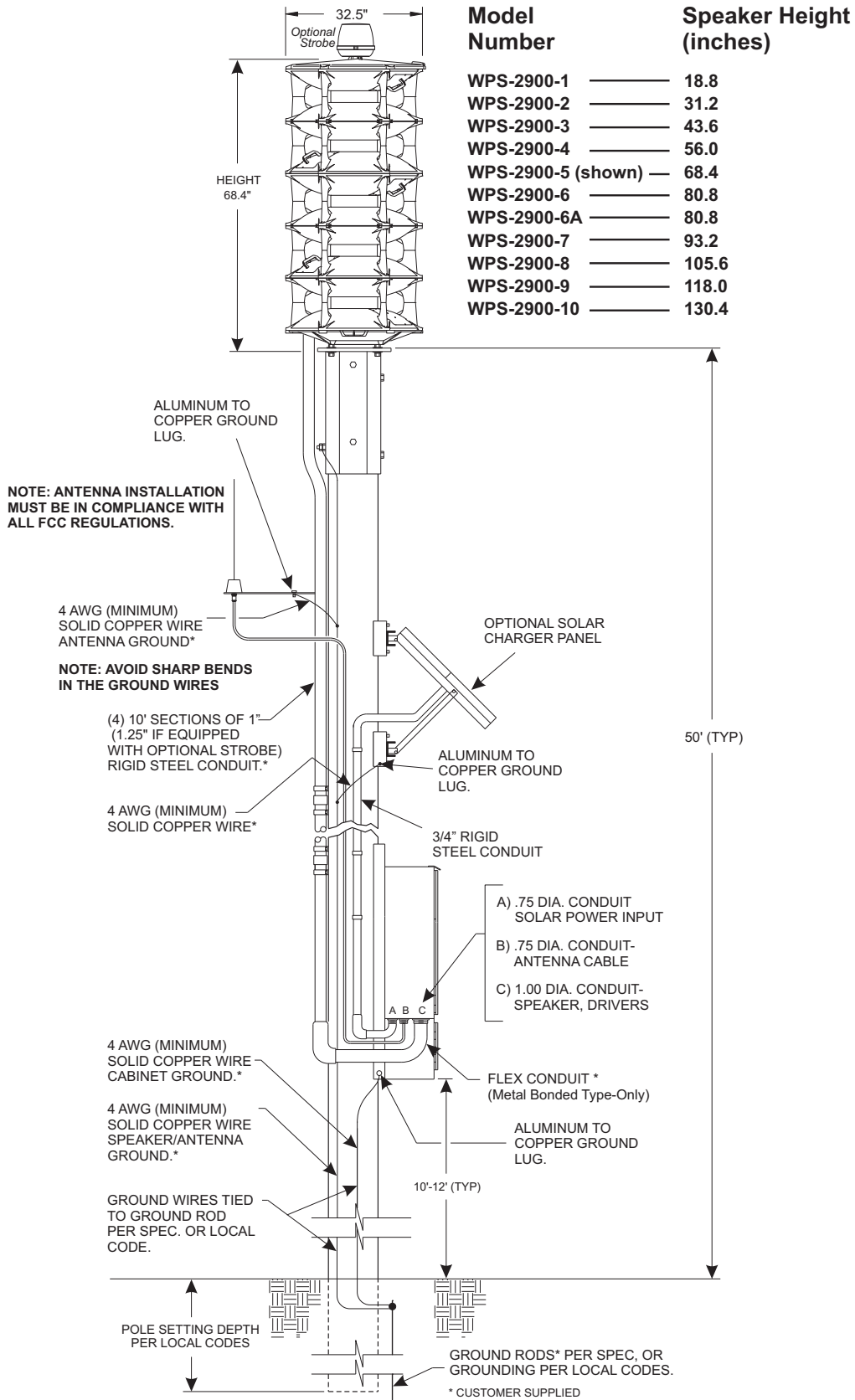

Fig. 2: Sample Station Drawing (Optional Solar Powered Battery Charger)



An Important Note to the Installation Technicians...

The installation of this product requires careful planning and attention to detail! The installation of this system should NOT be attempted by individuals without experience in the disciplines necessary to this procedure (i.e. High-voltage electrical wiring, utility pole installation, etc.).

The installation of the WPS-2900 station provided in this manual follows a logical progression. This process is not arbitrary! It was developed using information gathered from both the manufacturer and experienced field technicians. Deviations from any of these procedures are not recommended unless they are in contradiction with local codes. **IN ALL INSTANCES, LOCAL CODES TAKE PRECEDENT OVER PROCEDURES OUTLINED HEREIN.**

It is the responsibility of the installation technicians to read this entire manual. The installation procedure should not begin until all personnel are familiar with the entire process. The overall process includes the following:

Installation sequence for 5 or less cells

1. Site Selection
2. Utility Pole Preparation
3. Mount Pole Top Bracket and Ground Wire
4. Mount Electronic Cabinet to Pole
5. Mount Siren Assembly to Pole Top Bracket and Conduit to Pole
6. Set Utility Pole
7. Prepare and Mount Antenna Assembly (if present)
8. Prepare and Mount Solar Panels and Conduit (if present)
9. Installation of AC or Solar Service and Batteries
10. Confirm Proper System Operation

Installation sequence for 6 or more cells

1. Site Selection
2. Utility Pole Preparation
3. Mount Pole Top Bracket and Ground Wire
4. Mount Electronic Cabinet to Pole
5. Set Utility Pole
6. Mount Siren Assembly to Pole Top Bracket and Conduit to Pole
7. Prepare and Mount Antenna Assembly (if present)
8. Prepare and Mount Solar Panels and Conduit (if present)
9. Installation of AC or Solar Service and Batteries
10. Confirm Proper System Operation

Speaker assemblies consisting of eight (8) or more cells are shipped in two sections. The upper section must be mounted onto the lower section before the completed assembly can be mounted onto the pole.

This procedure is best performed with the lower section secured to its shipping pallet. Remove the shipping lid from the lower section before proceeding.

IMPORTANT! When placing the upper section onto the lower section, be sure to rotate the upper section so that the speaker driver is oriented 180° (farthest away) from the speaker driver for the next lowest cell.

NOTE: It is critical that the hardware used to connect the upper and lower sections is assembled in the order outlined here.

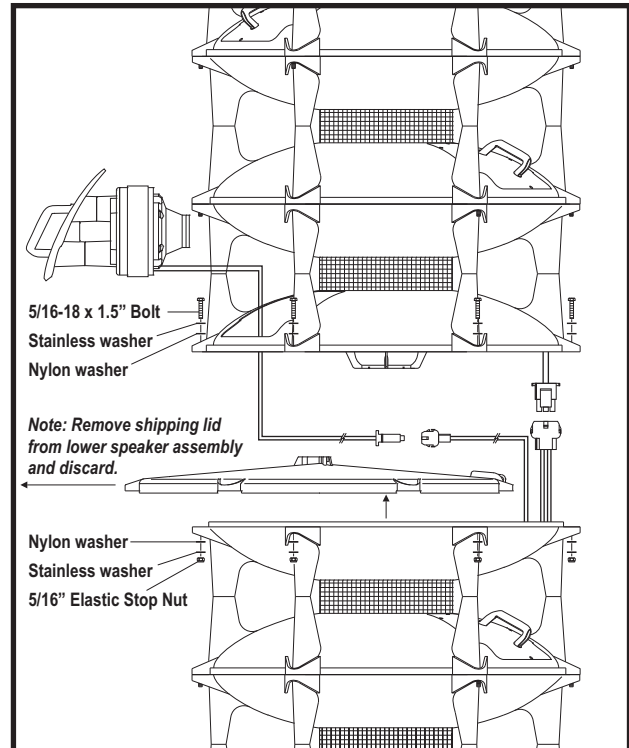

1. Locate the 5/16-18 x 1.5" bolt. Install the stainless washer washer onto this bolt. Now install the nylon washer onto this bolt as well.
2. Insert the bolt/washers down through the aligned assembly holes. Install the nylon washer onto the bolt, followed by the stainless washer and finally the 5/16" elastic-stop nut.
3. Tighten this nut, but only until it is snug. Repeat this procedure for the remaining assembly holes (6 total).
4. Sequentially tighten this hardware (in 5 Lbs/Ft. increments) until an ultimate torque value of 15 Lbs./Ft. is achieved. Be sure to follow the torque sequence shown at right.
5. With the two sections now joined, plug the 2-position and 12-position connectors into their respective mating connectors. Confirm full connector engagement by squeezing the locking tabs until they 'click' into place. Secure the speaker driver (shown removed) onto its mounting location. Be sure that the driver properly engages the speaker horn and secure the assembly to the speaker using the hardware provided (#8 x 3/4"). Tighten these screws until a torque value of 6 Lbs./In. is achieved.

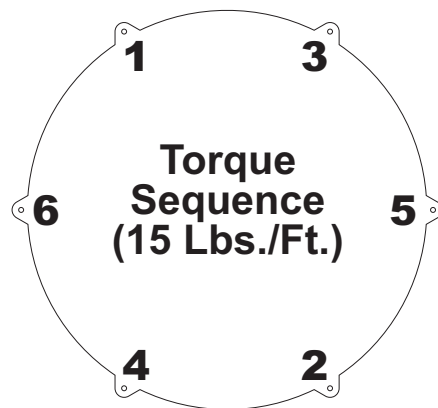

Section I: Site Selection

The site selection for the WPS-2900 requires careful consideration in order to achieve the optimum coverage of the siren station. For a guideline to system planning, sound propagation and site selection we direct the user to the Federal Emergency Management Agency's "Outdoor Warning Systems Guide, CPG 1-17."

The location of the siren site should be reviewed for its compatibility with its surroundings such as private homes, schools and hospitals. The user is cautioned to consider the use of hearing protection devices for service personnel working in close proximity to the speaker cluster.

Access to the siren site is important from the standpoint of service, maintenance inspection and access to a utility service connect.

Site locations for radio controlled units should be reviewed for radio reception.

Section II: Utility Pole Preparation...

a) Pole Selection

NOTE: This installation manual will address the procedures applicable to wooden utility poles of specific size and dimensions. Procedures for poles consisting of other materials (steel, concrete, etc.) are not addressed within this document. The information presented, however, provides the necessary data and guidelines for a successful installation regardless of pole material.

A WPS-2900 system consisting of 5 or less speaker cells may use a Class 2 or Class 1 utility pole. For systems consisting of 6 or more speaker cells, a Class 1 utility pole must be used. The length of the utility pole is consistent regardless of speaker cell quantity. The total length of the pole referenced within this document is 60 feet. The pole depth of the set pole is 10 feet, leaving a 50 foot pole as measured from the top of the pole to the ground. The utility pole should be set in accordance with local codes.

The inside area of the pole top mounting bracket will accept a pole that is no greater than 10.00" in diameter. On large scale projects, it is beneficial to order the pole to be "gained" to a top diameter of 9.5" +/- .50" for the top 30" section of the utility pole.

b) Component Dimensions

The utility pole may be pre-drilled prior to installation. The dimensions for all potentially mounted equipment are as follows:

Fig. 3: Pole Top Mounting Bracket Dimensions

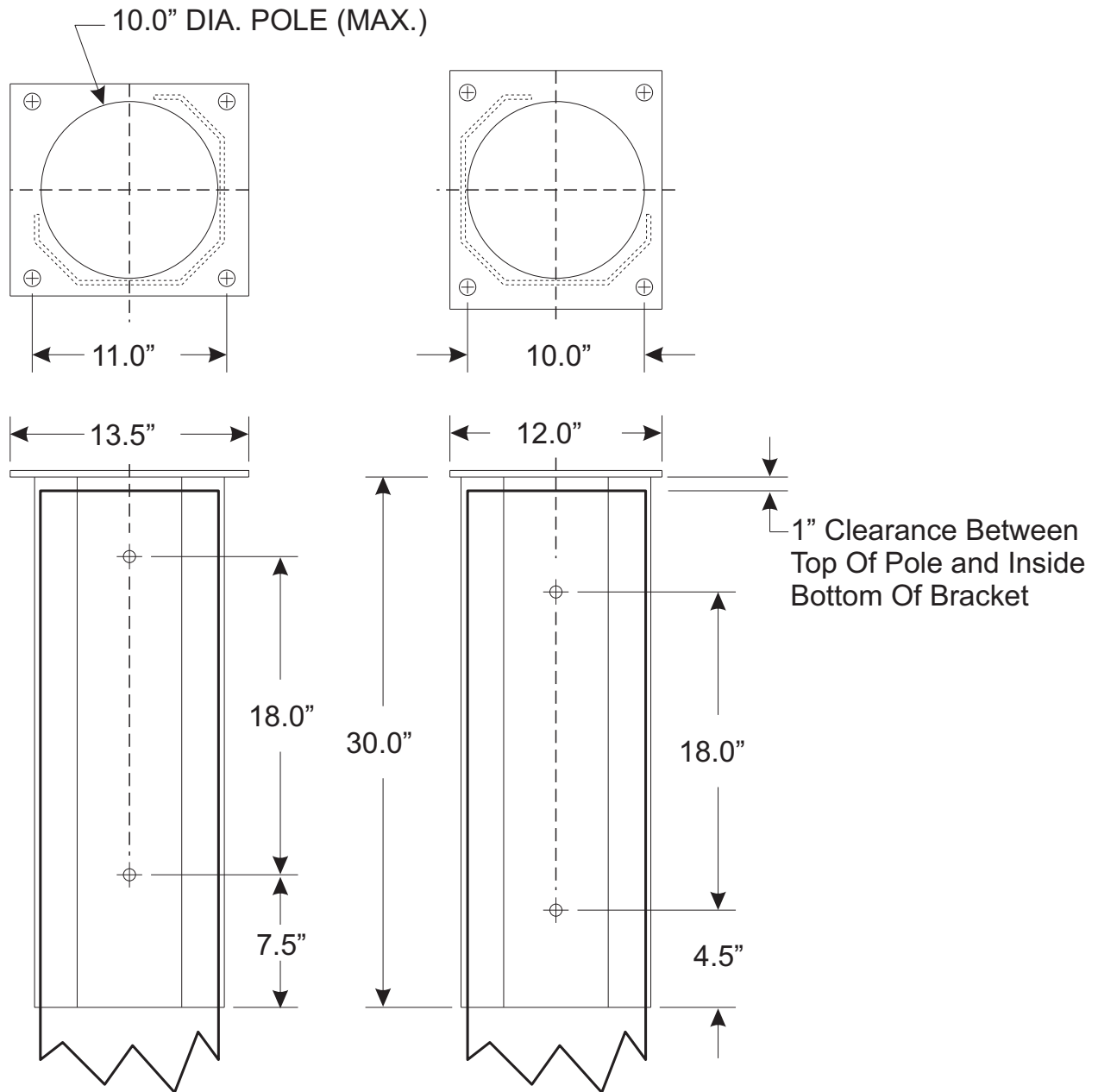

Fig. 4: Type II Electronic Cabinet Dimensions

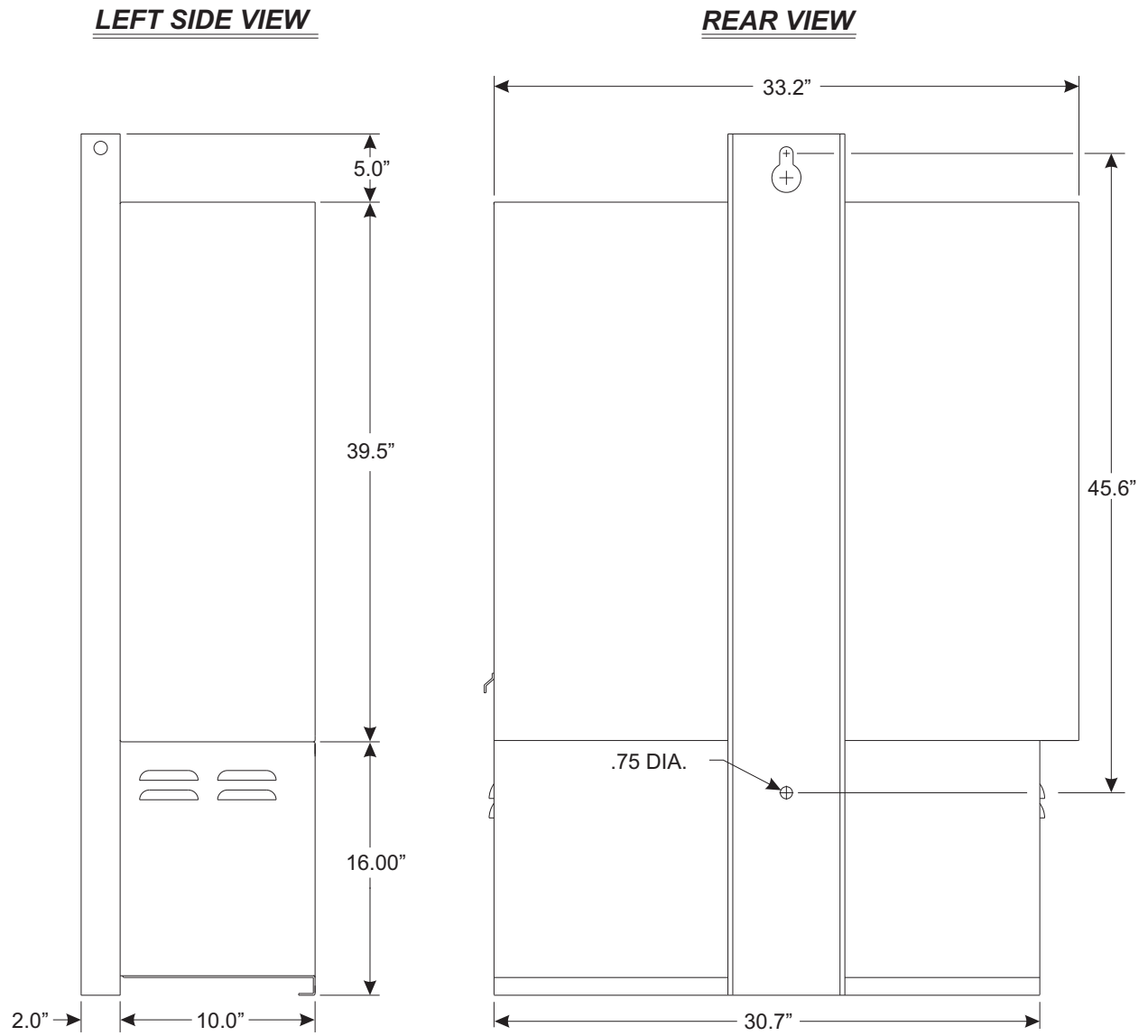

Fig. 5: Type III Electronic Cabinet Dimensions

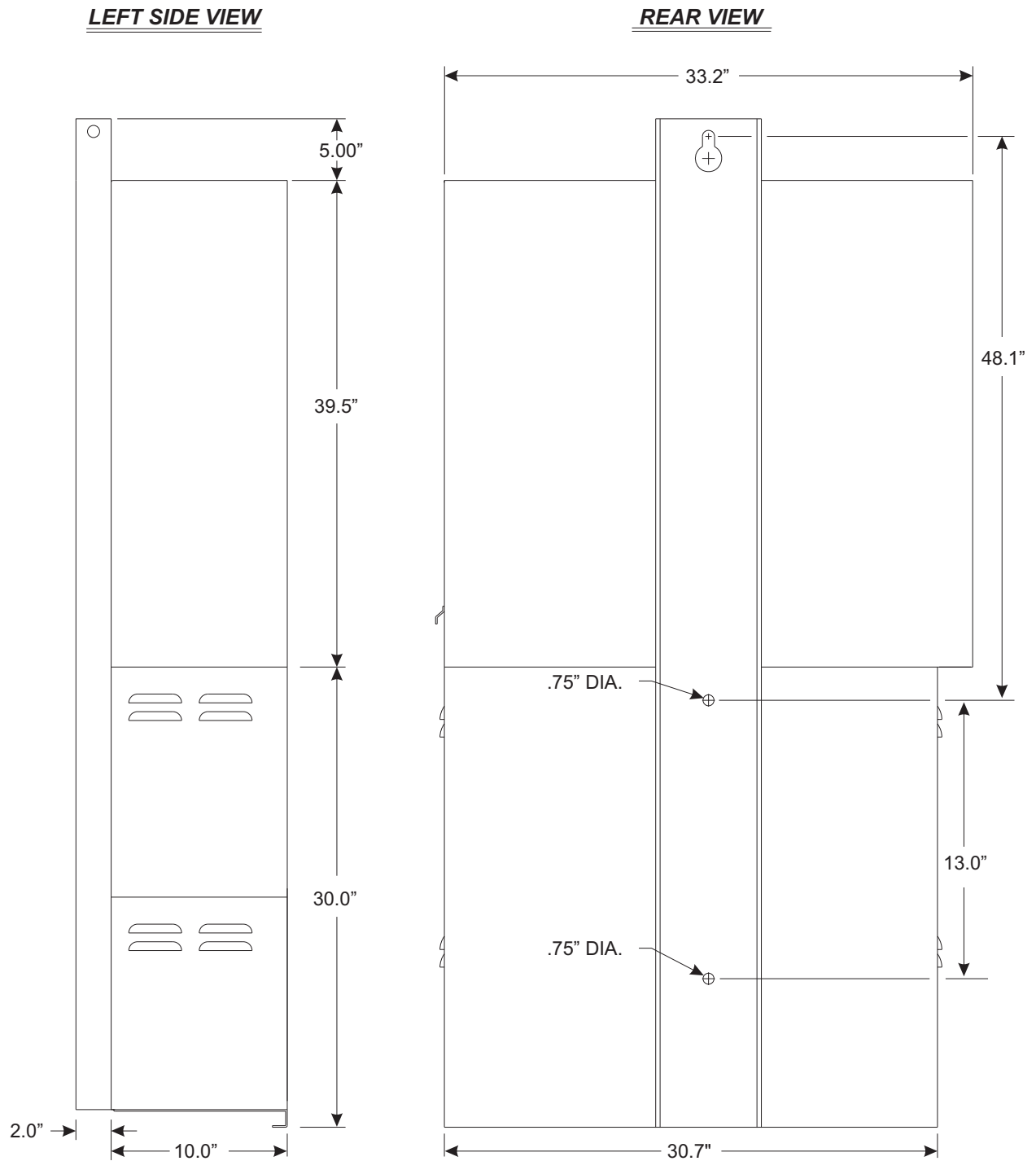
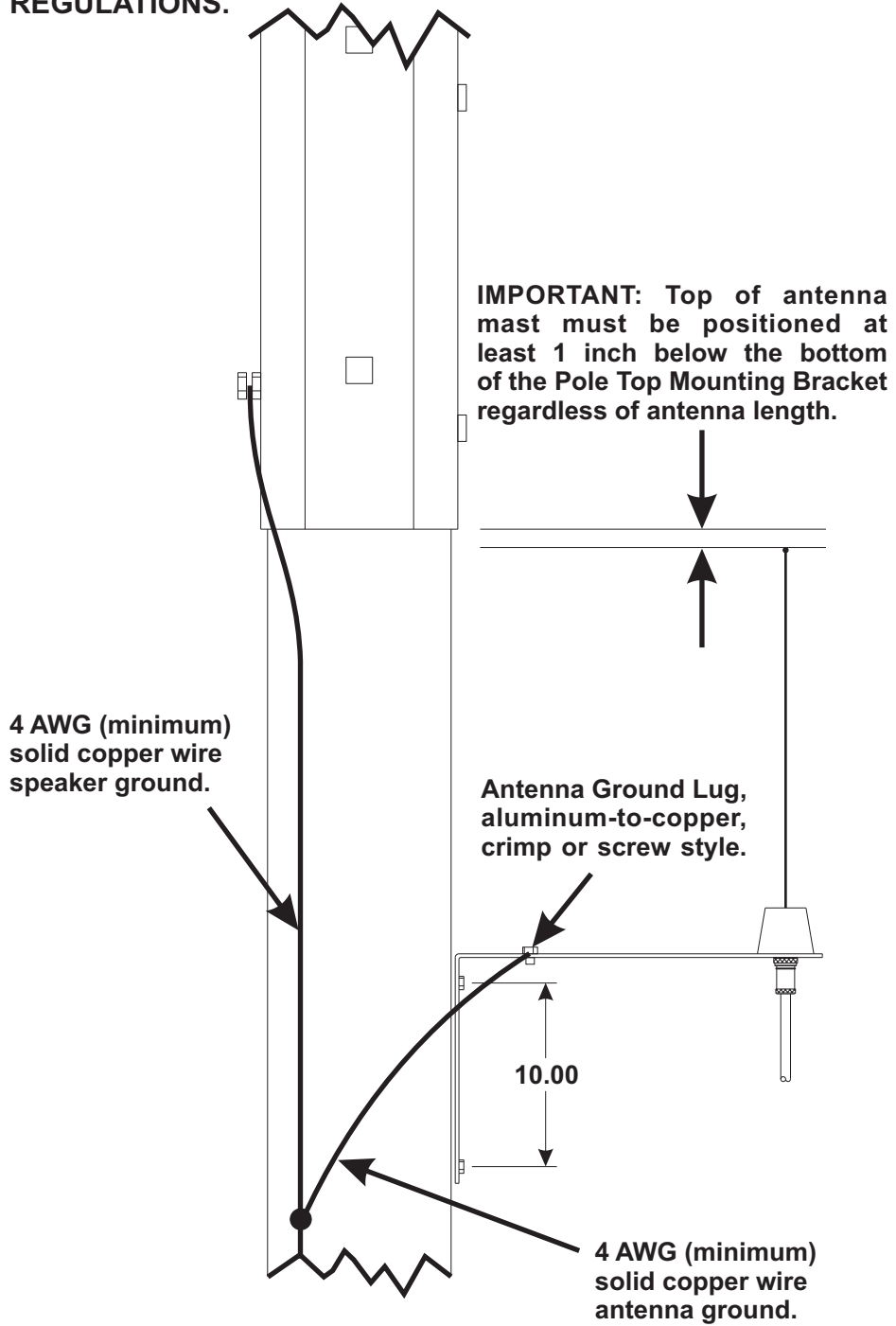

Fig. 6: Antenna Mounting Bracket Dimensions

NOTE: Antenna installation must be in compliance with all FCC REGULATIONS.



Section III: Equipment Mounting

a) Pole Top Bracket Installation...

Items Required for installation (not included)....

- (4) 5/8" x 14" Hex or Square head mounting bolts**
- (4) 5/8" Hex or Square head nuts**
- (8) 5/8" Flat Washer sized for the above referenced mounting bolt**
- (4) 5/8" Lock Washer**

- 1. Position the WPS-2900 pole top mounting bracket onto the top of the pole (see "Fig. 7: Pole Top Mounting Bracket" on page 15). Make sure there is a 1 inch space between the top of the pole and the pole top mounting bracket (see "Fig. 3: Pole Top Mounting Bracket Dimensions" on page 10).**

NOTE: The inside area of the pole top mounting bracket will accept a pole that is no greater than 10.00" in diameter. On large scale projects, it is beneficial to order the pole to be "gained" to a top diameter of 9.5" +/- .50" for the top 30" section of the utility pole.

- 2. Using the pole top mounting bracket as a guide, drill four mounting holes through the pole at the bracket mounting hole locations. These holes should be sized to accommodate the above referenced hardware.**
- 3. Secure the bracket to the pole using the prescribed hardware (see "Fig. 7: Pole Top Mounting Bracket" on page 15). Be sure to position all the associated hardware items in their proper order.**
- 4. Secure a length of #4 solid copper wire to the pole top bracket grounding lug using the supplied nut. Make sure that this wire is of sufficient length to reach the ground when the pole has been set.**

NOTE: All Hardware used for connecting equipment to the utility pole should be inspected for tightness between 12 to 18 months after installation. Some shrinkage of the newly treated utility pole may occur, loosening connections.

Fig. 7: Pole Top Mounting Bracket

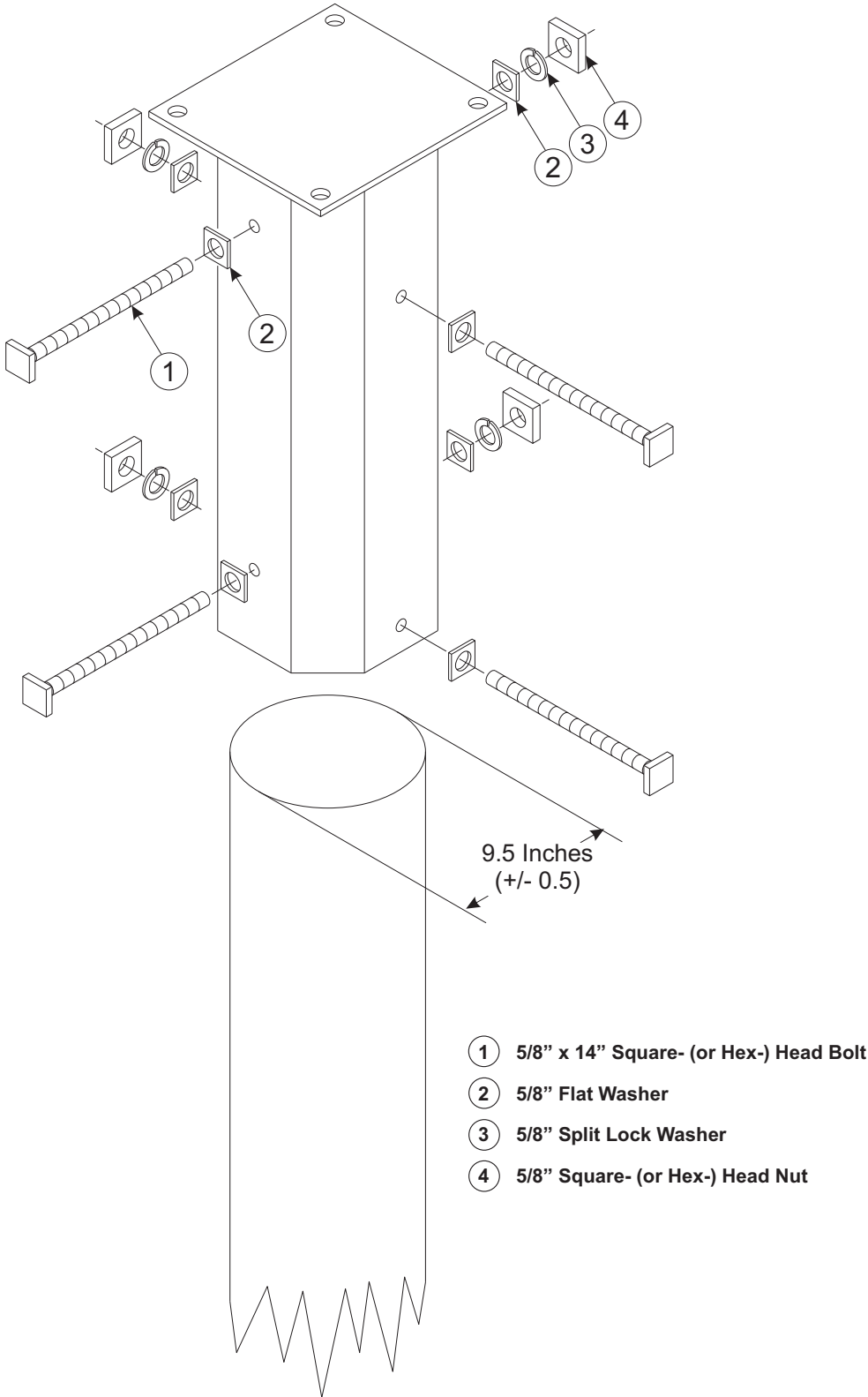

b) Electronic Cabinet Mounting and Siren Connections...

Mounting

Items Required for installation (not included)....

For Type II & III cabinets

<u>Qty.</u> <u>(Type II)</u>	<u>Qty.</u> <u>(Type III)</u>	<u>Description</u>
(2)	(3)	5/8" x 14" Hex or Square head mounting bolts
(4)	(6)	5/8" Flat Washer sized for the above mounting bolt
(2)	(3)	5/8" Split-Lock Washer
(2)	(3)	5/8" Hex or Square head nuts
(1)	(1)	Aluminum-to-Copper lug sized for #4 ground wire (crimp or screw style)
(1)	(1)	Stainless Steel 1/4-20 x 2" bolt with appropriately sized flat washer, split-lock washer and nut
(1)	(1)	10' Copper ground rod

Fig. 8: Electronic Cabinet Mounting (Side View)

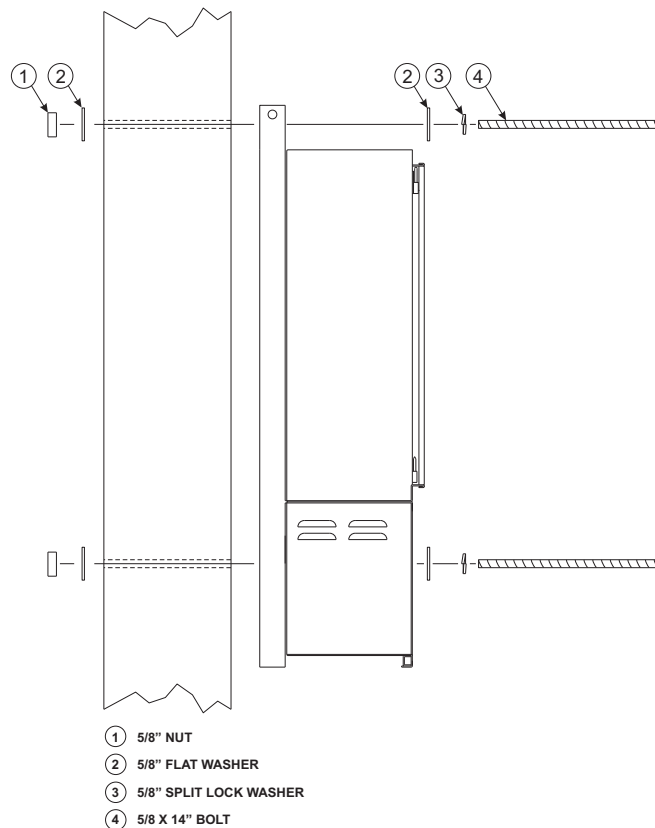

The WPS-2900 siren case assembly may be installed onto the pole and wired before setting the pole.

NOTE: Note: Due to the weight of the siren amplifier panel, the electronic cabinet assembly must be transported in an upright fashion to prevent distortion of the amplifier panel.

1. It is necessary for the installer to remember that two factors should determine the optimum mounting location; the desired distance of the mounted cabinet to the ground (typically 10 to 12 feet as measured from the bottom of the cabinet) and available speaker wire length (speaker assemblies are provided with a minimum of 50 feet of speaker wire as measured from the bottom of the speaker assembly).
2. After the mounting location has been determined, drill an appropriately sized thru-hole into the pole at the top cabinet mounting hole. Install a bolt loosely into the hole and hang the cabinet onto the bolt.
3. With the cabinet fitted snugly to the pole, mark the surface of the pole at the lower mounting hole location inside the battery storage compartment. Type III cabinets will have an additional mounting hole located in the second battery storage compartment (see “Fig. 5: Type III Electronic Cabinet Dimensions” on page 12). Remove the cabinet from the pole and drill an appropriately sized thru-hole into the pole at the location(s) marked. Return the cabinet to its mounting location and secure to the pole using the specified hardware.
4. Install an aluminum-to-copper lug (crimp or screw style) onto the #4 solid copper wire. Secure this to the cabinet mounting channel in hole supplied using stainless steel 1/4 - 20 hardware.
5. Install the ground rod as specified by local codes and connect both copper wires (from pole top mounting bracket and electronic cabinet) to this rod.
6. Install rigid steel conduit and necessary couplings from the speaker’s 1” conduit adapter to the 1” speaker conduit protruding from the base of the siren case assembly. Beacon-equipped speakers will require the use of 1.25” speaker conduit and the necessary adapters for connection to both the 1” speaker base and 1” siren case assembly. The first section of conduit may be installed onto the speaker’s base casting prior to mounting the speaker to the pole top bracket. At the option of the user, conduit unions may be used between the first section of conduit and the speaker base casting and at the speaker cable conduit entrance to the siren case assembly.

NOTE: If the location of the conduit on the pole requires difficult conduit bends or couplings, a section of metal bonded seal tight conduit NOT TO EXCEED 24 INCHES may be used at the top of the pole and/or at the bottom of the pole as needed for the speaker cable installation.

Batteries for the system should not be installed until the siren station is set in place, otherwise some leakage of the battery fluid may occur. Batteries should not be connected to the system until AC power (or solar power if equipped) is available to the system to operate the system’s battery charger.

IMPORTANT! Before proceeding with the speaker installation, it is necessary for the installer to know the number of speaker cells to be installed on the utility pole. If the speaker assembly to be installed consists of 5 (five) or less speaker cells, the speaker assembly may, at the installers discretion, be mounted onto the utility pole before the pole has been set. Siren assemblies consisting of 6 (six) or more speaker cells require the utility pole to be set prior to mounting. These larger assemblies also require a special mounting procedure that must be followed to avoid damaging the assembly. Both procedures are outlined in the following sections.

c) Siren Assembly Mounting (5 or less speaker cells)...

Hardware required for installation (factory included)....

- (8) 3/4"-10 hex head nuts**
- (8) 7/8" Flat Washers**
- (4) 3/4" Split Lock Washers**

- 1. Sling or cradle the utility pole in a safe manner so that the pole top is 3 to 4 feet off the ground. This will allow the speaker assembly to clear the ground when installed.**
- 2. Locate the 4 mounting studs on the bottom of the speaker assembly (see "Fig. 9: Siren to Pole Top Mounting Bracket (Side View)" on page 20).**
- 3. Thread a 3/4" hex nut onto each of the mounting studs until there is approximately 1" of space between the top of the nuts and the bottom of the siren assembly. This space will allow the speaker assembly to be leveled once the pole has been set.**
- 4. Install a 7/8" flat washer onto each of the mounting studs.**
- 5. Insert the four mounting studs through the mounting holes on the top of the pole top bracket. The bottom of the siren assembly should lie flat against the pole top bracket.**
- 6. Install a 7/8" flat washer onto each of the mounting studs.**
- 7. Install a 3/4" split lock-washer onto each of the mounting studs.**
- 8. Thread a 3/4" hex nut onto each of the mounting studs. Tighten this nut firmly to secure the siren assembly to the pole top bracket.**

At this point the pole should now be set. However, the installer may use their own discretion as to whether to mount the electronic cabinet onto the utility pole before the pole is set.

When the pole has been set, use the adjustment nuts (indicated in step 2) to adjust the siren assembly until it is level.

d) Siren Assembly Mounting (6 or more speaker cells)...

Hardware required for installation (factory included)....

- (8) 3/4"-10 hex head nuts**
- (8) 7/8" Flat Washers**
- (4) 3/4" Split Lock Washers**

Items required (not included)

Crane, Bucket Truck or similar lifting device
Straps

The larger siren assemblies (6 or more speaker cells) may only be mounted onto the pole top bracket after the pole has been set. Due to their increased mass and size, these assemblies *must* be properly supported from the bottom of the assembly while being lifted into position. DO NOT ATTEMPT TO LIFT THE SIREN ASSEMBLY FROM THE TOP!

- 1. Locate the 4 mounting studs on the bottom of the speaker assembly (see "Fig. 9: Siren to Pole Top Mounting Bracket (Side View)" on page 20).**
- 2. Thread a 3/4" hex nut onto each of the mounting studs until there is approximately 1" of space between the top of the nuts and the bottom of the siren assembly. This space will allow the speaker assembly to be leveled once the pole has been set.**
- 3. Install a 7/8" flat washer onto each of the mounting studs.**
- 4. Insert the four mounting studs through the mounting holes on the top of the pole top bracket. The bottom of the siren assembly should lie flat against the pole top bracket.**
- 5. Install a 7/8" flat washer onto each of the mounting studs.**
- 6. Install a 3/4" split lock-washer onto each of the mounting studs.**
- 7. Thread a 3/4" hex nut onto each of the mounting studs. Tighten this nut firmly to secure the siren assembly to the pole top bracket.**
- 8. Use the adjustment nuts (indicated in step 2) to adjust the siren assembly until it is level.**

Fig. 9: Siren to Pole Top Mounting Bracket (Side View)

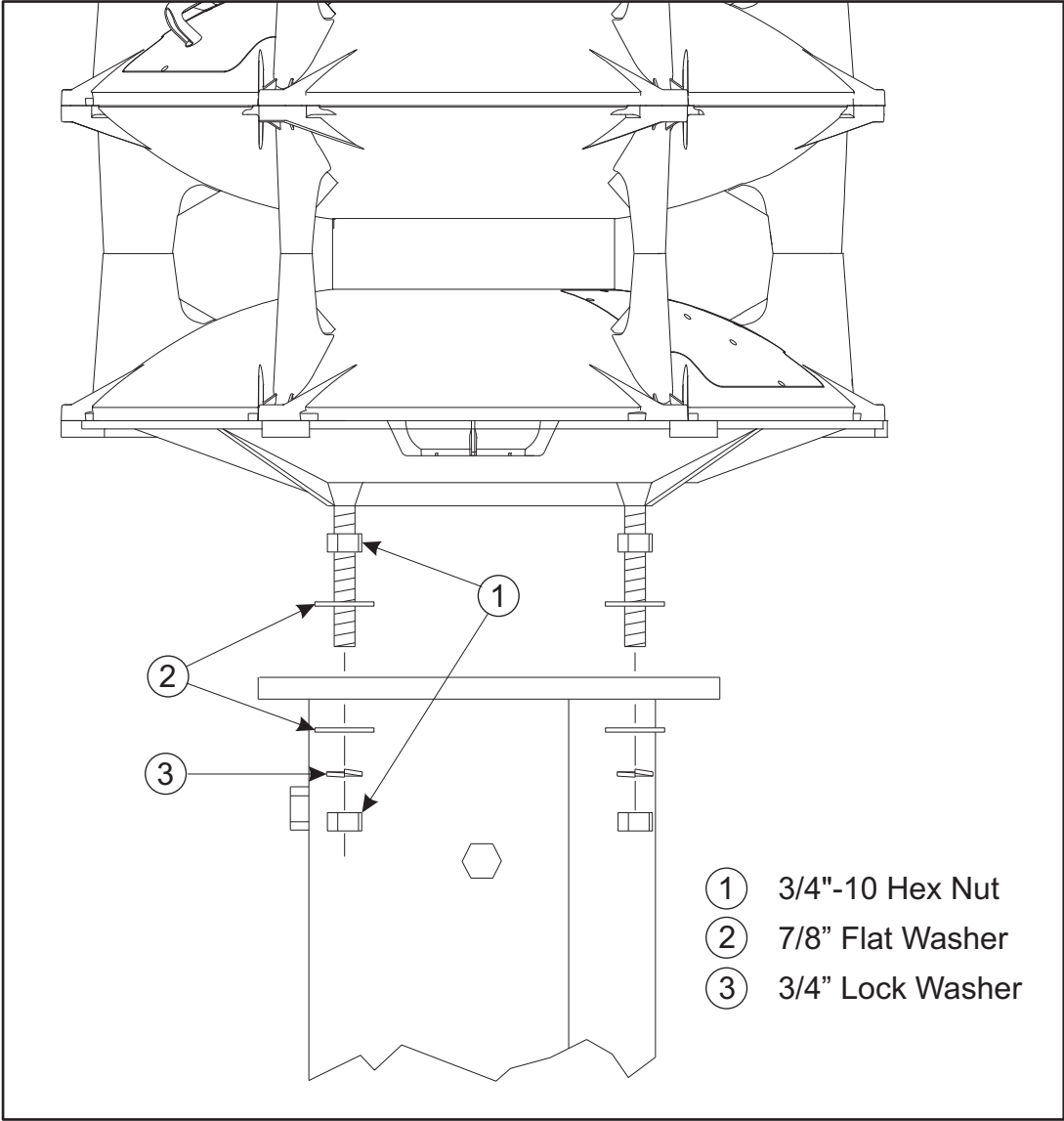

e) Antenna Mounting (optional)...

NOTE: Antenna installation must be in compliance with all FCC regulations.

The proper antenna bracket mounting location is determined by several considerations. The antenna bracket should be positioned as high on the utility pole as is possible. However, under no circumstances should the top of the installed antenna must be any closer than one inch from the bottom of the Pole Top Mounting Bracket (see “Fig. 6: Antenna Mounting Bracket Dimensions” on page 13). Be sure to ground the antenna bracket as shown using 4 AWG solid copper wire. The antenna cable provided by the factory is 35 feet in length.

It is also important to remember that the antenna **MUST** be mounted on the side of the utility pole that faces the transmitter (see below)

Fig. 10: Antenna Mounting Orientation

Improper Antenna Orientation

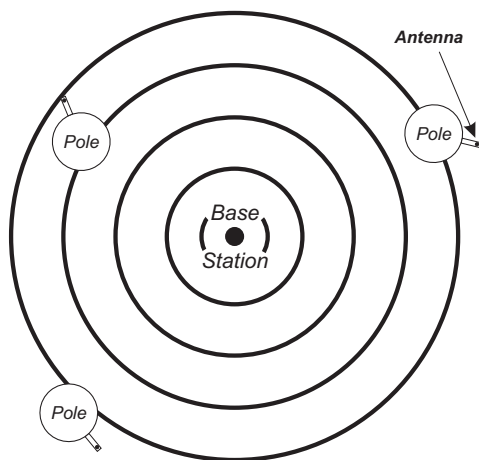

Correct Antenna Orientation

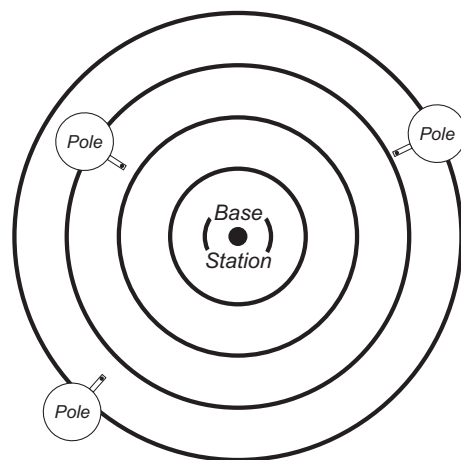

Refer to the installation sheet included with your antenna kit for further information regarding cable connections and antenna trimming.

f) Solar Panel Mounting (optional)...

The solar panel must be installed so that it is directly facing the earth's equator with an unobstructed view. Failure to orient the solar panel in this way will result in significantly reduced charging effectiveness.

The most critical aspect of properly mounting the solar panel involves achieving the optimum tilt angle. The tilt angle is determined by the distance between the upper and lower mounting brackets, as shown (see "Fig. 12: Solar Panel Mounting Views" on page 24).

Refer to page 23 for electrical connection information.

Refer to page 24 for general solar panel mounting.

Refer to page 25 for information on determining your specific mounting angle.

Run rigid steel conduit from the solar panel to the 3/4" AC knockout located at the bottom of the siren case assembly. A section of up to 24 inches of metal bonded seal tight conduit may be utilized where conduit connections to the solar panel or electronic cabinet are not conveniently accomplished with rigid steel conduit and fittings. This conduit should be sealed to prevent insects and pests from entering the siren case assembly.

Fig. 11: Solar Panel Wiring Connections

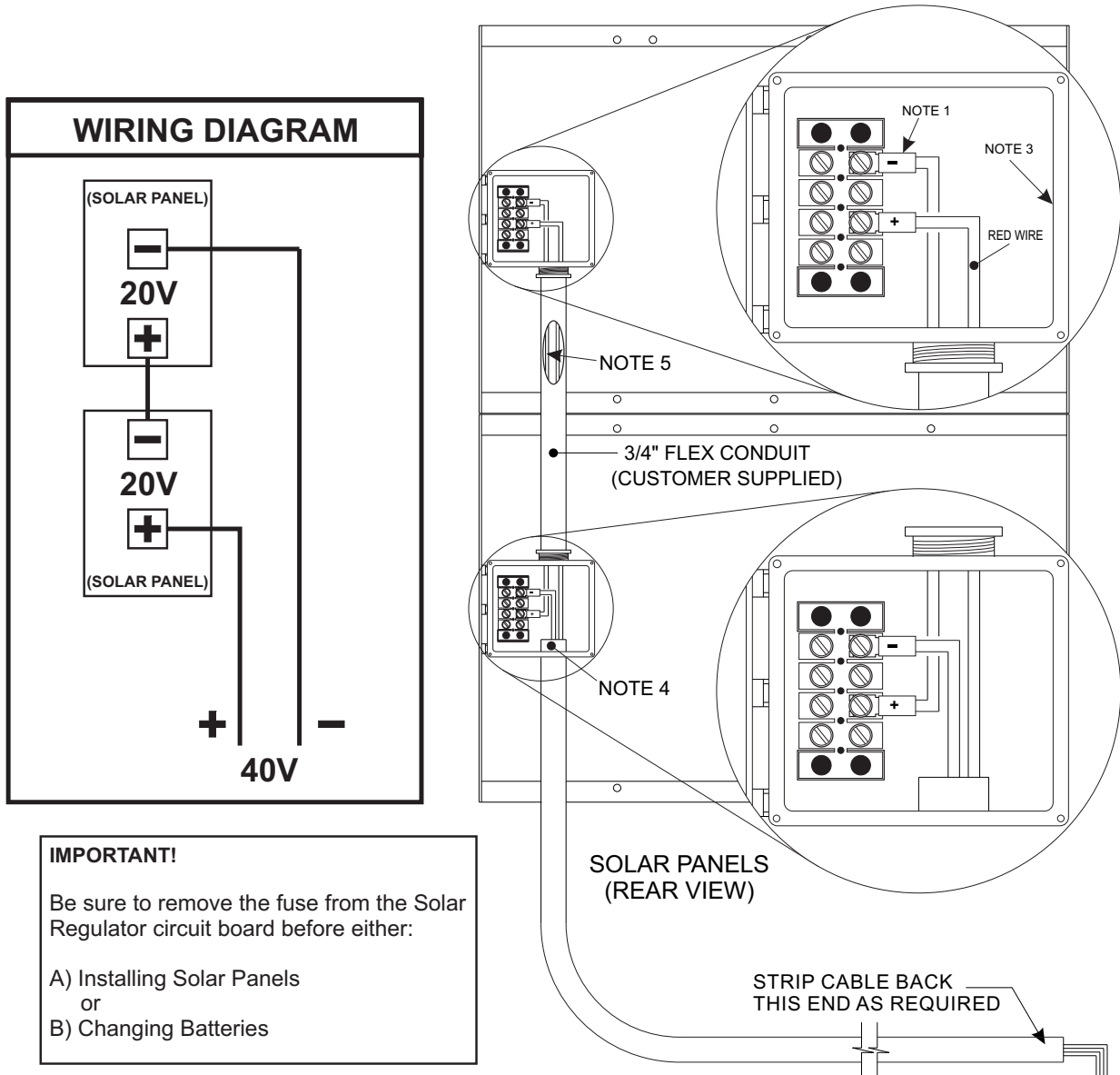

NOTES:

1. Always verify each solar panel's polarity with a volt meter before making any connections. The solar panels are to be wired together in series. Be sure to verify the solar panel specification of open circuit voltage measurement (approx. 20VDC). When properly wired together in series, the voltage measurement on the wires feeding the Solar Regulator will measure approx. 40VDC in open circuit.
2. Wire entrance hardware per local codes, water tight as required (3 places).
3. Electrical boxes shown with covers removed.
4. Cable to be stripped back 26" at solar panel end.
5. Supplied by Whelen, included with installation kit.

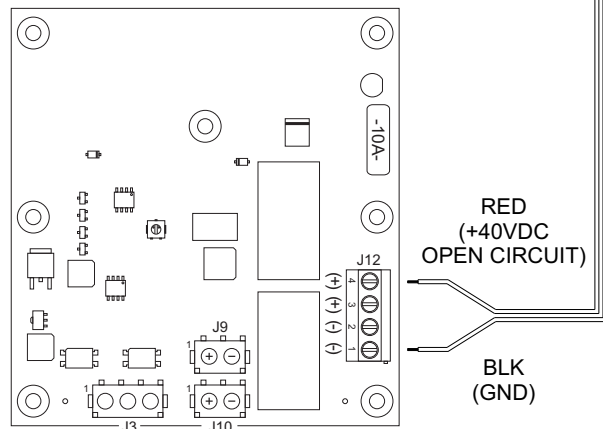
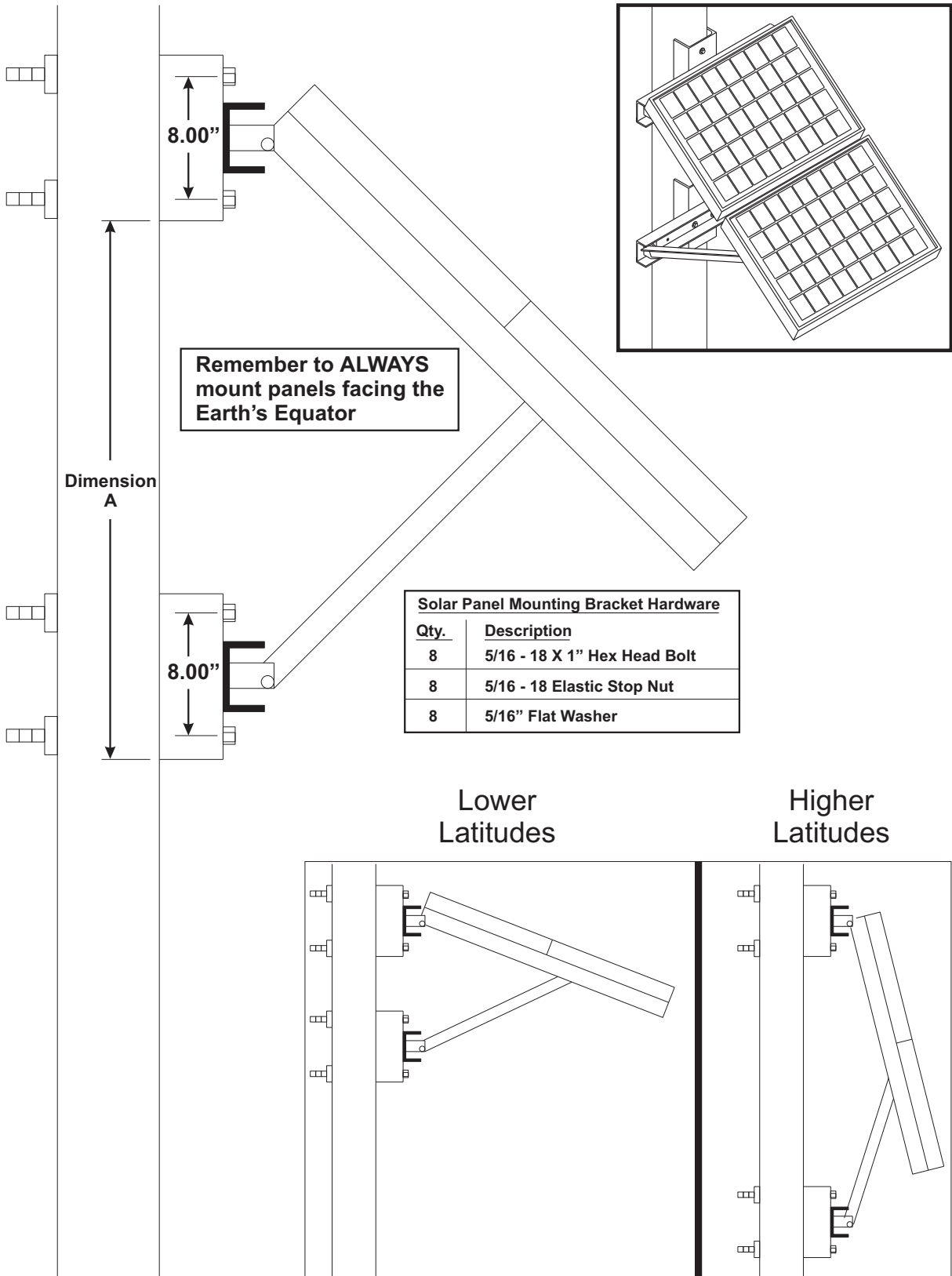

Fig. 12: Solar Panel Mounting Views



g) Determining Solar Panel Mounting Angle

1. Determine the *Latitude* of your location.
2. Find your *Latitude* on the table below and note the corresponding *Tilt Angle*.

<u>LATITUDE</u>	<u>TILT ANGLE</u>
0° to 9°	75° = Tilt Angle
10° to 20°	85° minus LATITUDE = Tilt Angle
21° to 45°	80° minus LATITUDE = Tilt Angle
46° to 65°	75° minus LATITUDE = Tilt Angle
66° to 75°	10° minus LATITUDE = Tilt Angle

3. Locate your TILT ANGLE in the list below. For every TILT ANGLE, there is a corresponding “Dimension A”. “Dimension A” represents the distance from the bottom of the upper mounting bracket to the bottom of the lower mounting bracket.

example 1:

Location LATITUDE is 30°

80° - 30° = 50° Tilt Angle

50° Tilt Angle = 33.60” Dimension A

example 2:

Location LATITUDE is 7°

7° = 75° Tilt Angle

75° Tilt Angle = 15.54” Dimension A

Tilt Angle	Dimension A (inches)	Tilt Angle	Dimension A (inches)	Tilt Angle	Dimension A (inches)
10	50.49	32	43.71	54	30.93
11	50.34	33	43.24	55	30.24
12	50.16	34	42.77	56	29.54
13	49.97	35	42.28	57	28.84
14	49.77	36	41.78	58	28.13
15	49.55	37	41.26	59	27.41
16	49.32	38	40.74	60	26.69
17	49.08	39	40.20	61	25.96
18	48.82	40	39.65	62	25.23
19	48.54	41	39.10	63	24.50
20	48.25	42	38.53	64	23.76
21	47.95	43	37.95	65	23.01
22	47.63	44	37.36	66	22.27
23	47.30	45	36.75	67	21.52
24	46.95	46	36.14	68	20.77
25	46.59	47	35.52	69	20.02
26	46.22	48	34.89	70	19.27
27	45.83	49	34.25	71	18.52
28	45.43	50	33.60	72	17.77
29	45.02	51	32.95	73	17.02
30	44.60	52	32.28	74	16.28
31	44.16	53	31.61	75	15.54

Section IV: Wiring

a) Siren Connections

The type of speaker harness you receive depends on the number of speaker cells present. For systems consisting of 1 to 5 speaker cells, a 5-pair harness cable is provided. This cable has 5 BLACK wires numbered 1 to 5 and 5 RED wires numbered 1 to 5. For systems with 6 to 10 speaker cells, a 10-pair harness cable is used. This wires in this cable are designated as follows:

10 BLACK wires numbered 1 to 10

10 RED wires numbered 1 to 10

In systems with unused wires, dress the unused wires so they are out of the way. Do not cut these wires, as they can be used to replace damaged wires in the future.

NOTE: The following procedure provides the information necessary for successfully connecting the siren harness wires to their designated amplifiers. Depending upon the distance between the siren base and the electronic cabinet, there will be varying lengths of wire remaining in the cabinet. It is the installers responsibility to properly trim and dress these wires in a fashion that not only leaves the wires organized, but also includes a service loop of suitable length.

1. Locate the siren wiring harness where it enters the electronic cabinet.
2. Locate the BLACK and RED wires marked 1 on their insulation. These wires are designated for connection to siren amplifier 1.
3. Route these wires through the cabinet's wire loom and connect to Amp 1 (see "Fig. 13: Siren Amplifier Connections" on page 27).
4. Repeat steps 2 and 3, substituting the appropriate number for all remaining amplifiers.
5. When all amplifiers have been wired, install loom cover.

Authors Note: Prior to this writing, systems with 6 to 9 speaker cells received a 9-pair harness cable, with Red and Black wires numbered 1 to 9. Systems with 10 speaker cells received two, 5-pair cables. One cable used Red and Black wires numbered 1 to 5, while the remaining cable used Red and Black wires numbered 1A to 5A (to be used for amplifiers 6 thru 10).

Fig. 13: Siren Amplifier Connections

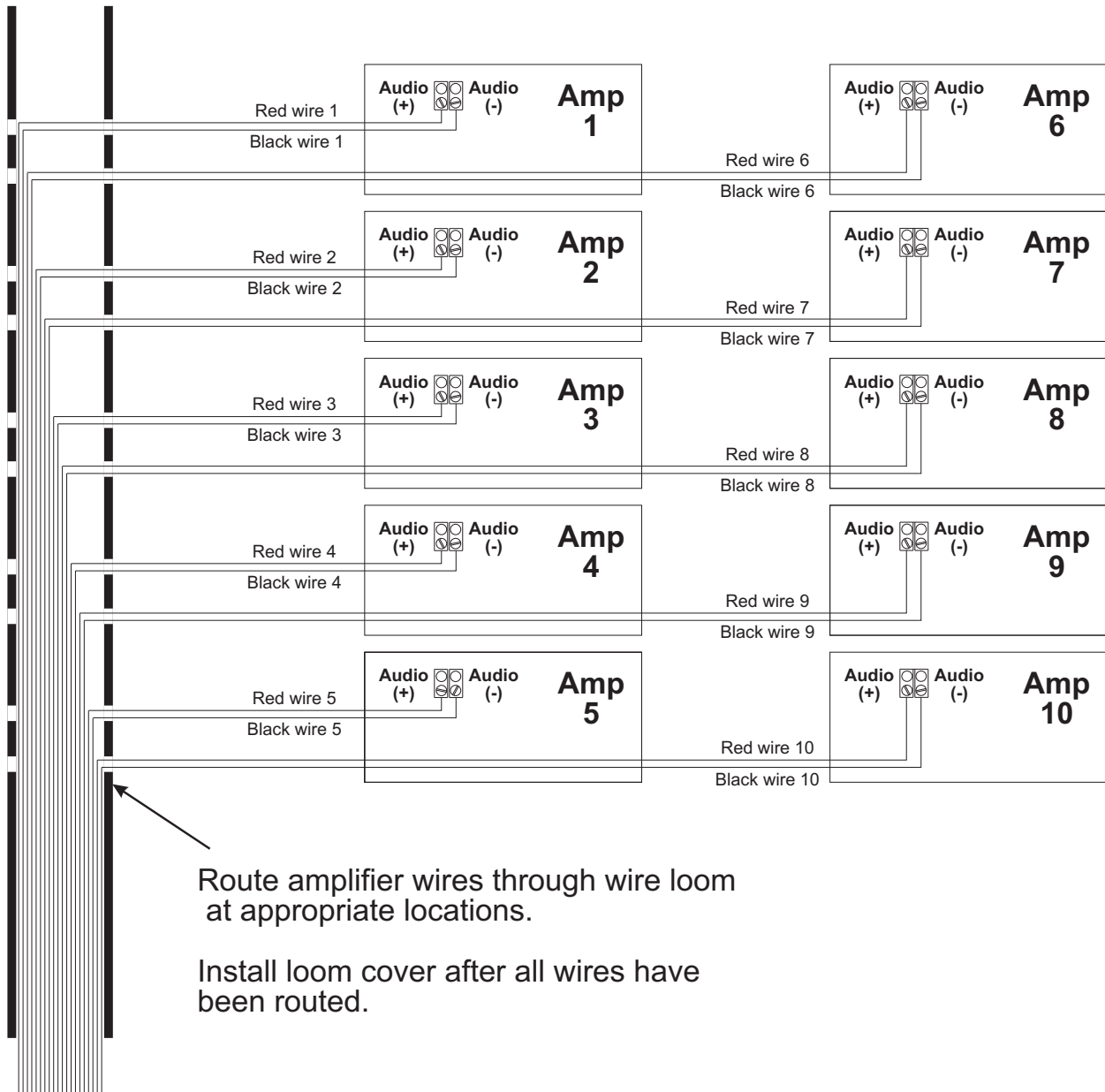

b) AC Wiring

An AC Service (Single Phase only) with an acceptable disconnect is required. A 15 amp (minimum) 120 VAC circuit is recommended.

Locate the service on the pole according to local codes, taking care that the service entrance will meet height requirements once the pole is set into place.

The WPS-2900 includes a 15 amp, 120 VAC outlet. The cabinet's battery charger plugs into one of the receptacles. The remaining receptacle is available for use by service personnel (see "Fig. 14: AC Outlet Installation" on page 29).

NOTE: A section of up to 24 inches of metal bonded seal tight conduit may be utilized where conduit connections to the siren case assembly are not conveniently accomplished with rigid steel conduit and fittings.

Each WPS-2900 siren system is supplied with a Lightning arrestor which is to be installed on the AC service. Local codes should be reviewed and followed to establish the connection of this device on the primary or secondary side of the disconnect.

NOTE: The location of the siren site should be reviewed for the quality of the AC service. AC power sources that are subject to excessive power surges or transients are not acceptable.

The AC charger is simply plugged into an AC duplex outlet (factory included) installed as follows:

1. Remove the cover from the 4" x 4" box.
2. Position the 3/4" knock-out in the box above the 3/4" knockout in the cabinet.
3. Attach a flex fitting (not included) through the cabinet and the box. This will secure the box to the cabinet.
4. Connect the AC service to the leads on the cover assembly.
5. Attach the cover to the box.
6. Attach ground wire (GREEN) to cabinet ground stud above the installed outlet.

Fig. 14: AC Outlet Installation

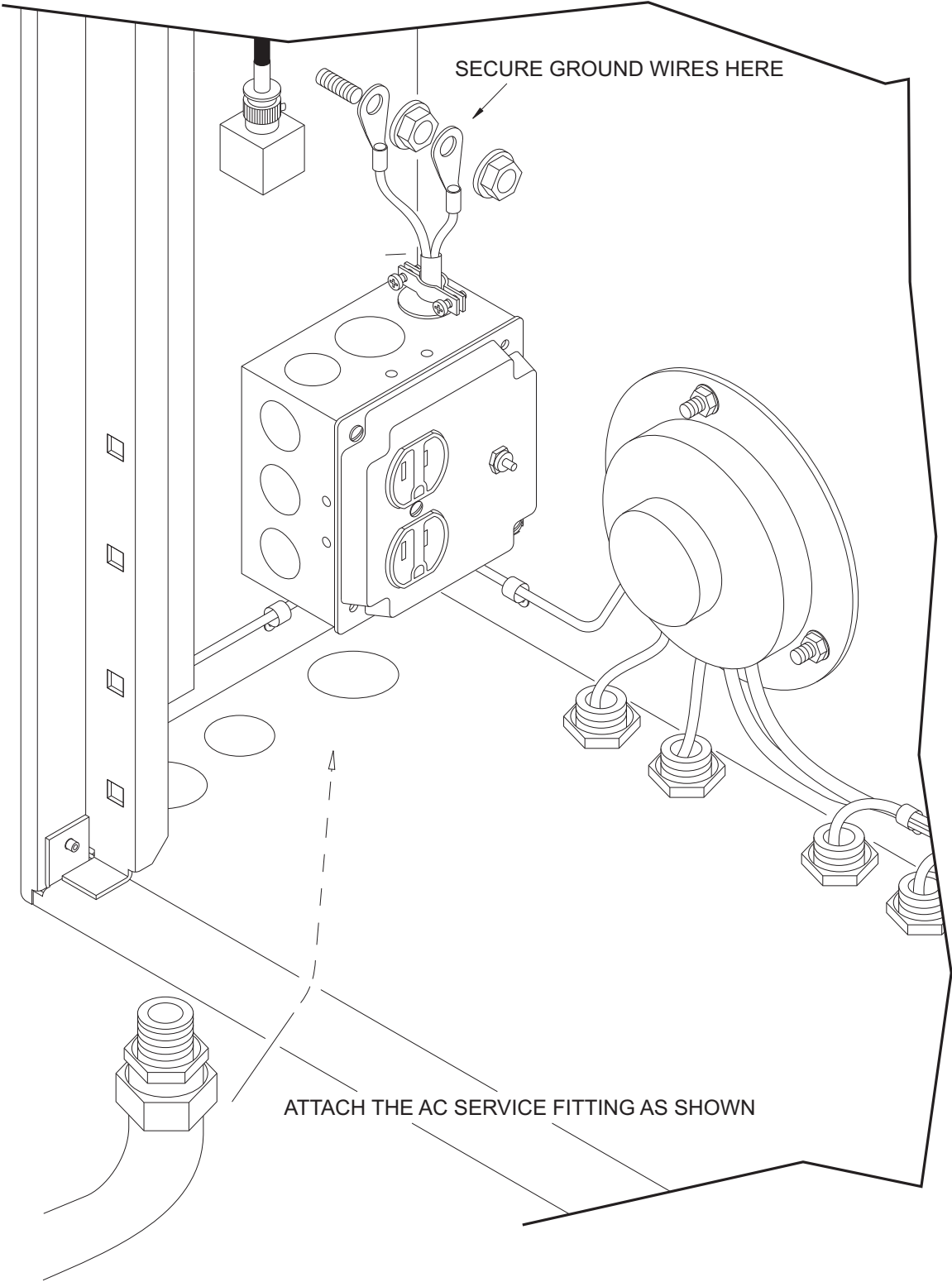

c) Batteries

1. **Make sure that the system battery switch is in the OFF position.**
2. **Install the batteries included with your system and connect them as shown in the illustration representing your cabinet type. MAKE SURE TO OBSERVE THE POLARITY OF THE TERMINALS BEFORE MAKING ANY CONNECTIONS.**

NOTE: For battery wiring, DC wiring conventions are used (BLACK is ground (-)).

For Type II Cabinets (see “Fig. 15: Battery Connections (Type II Cabinet)” on page 31)

Type III Cabinets (see “Fig. 16: Battery Connections (Type III Cabinet)” on page 32)

3. **Rotate the system battery switch to the ON position.**
4. **Plug the battery charger into the AC outlet.**
5. **Verify system operation as outlined in the system maintenance check list.**

Fig. 15: Battery Connections (Type II Cabinet)

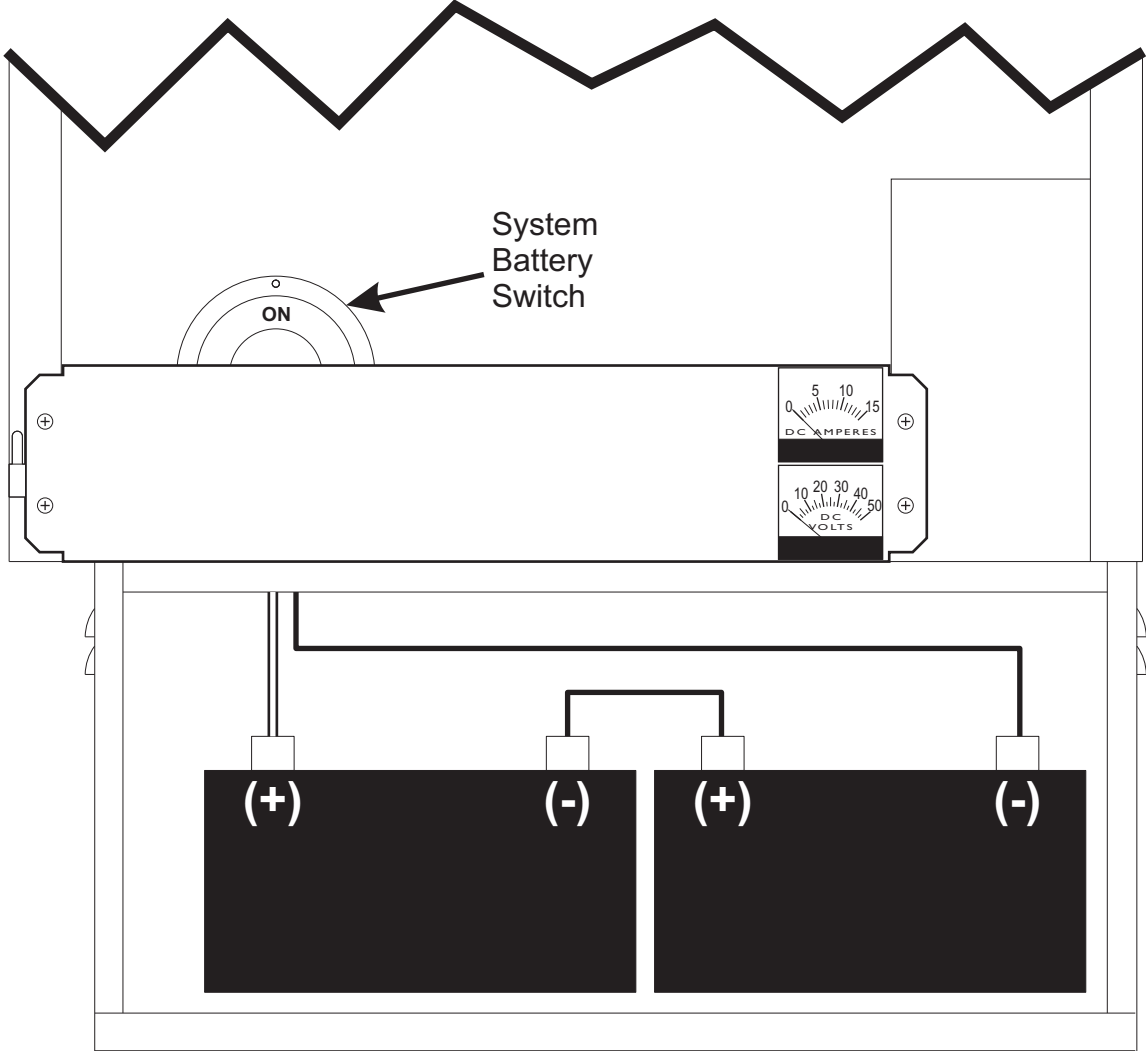
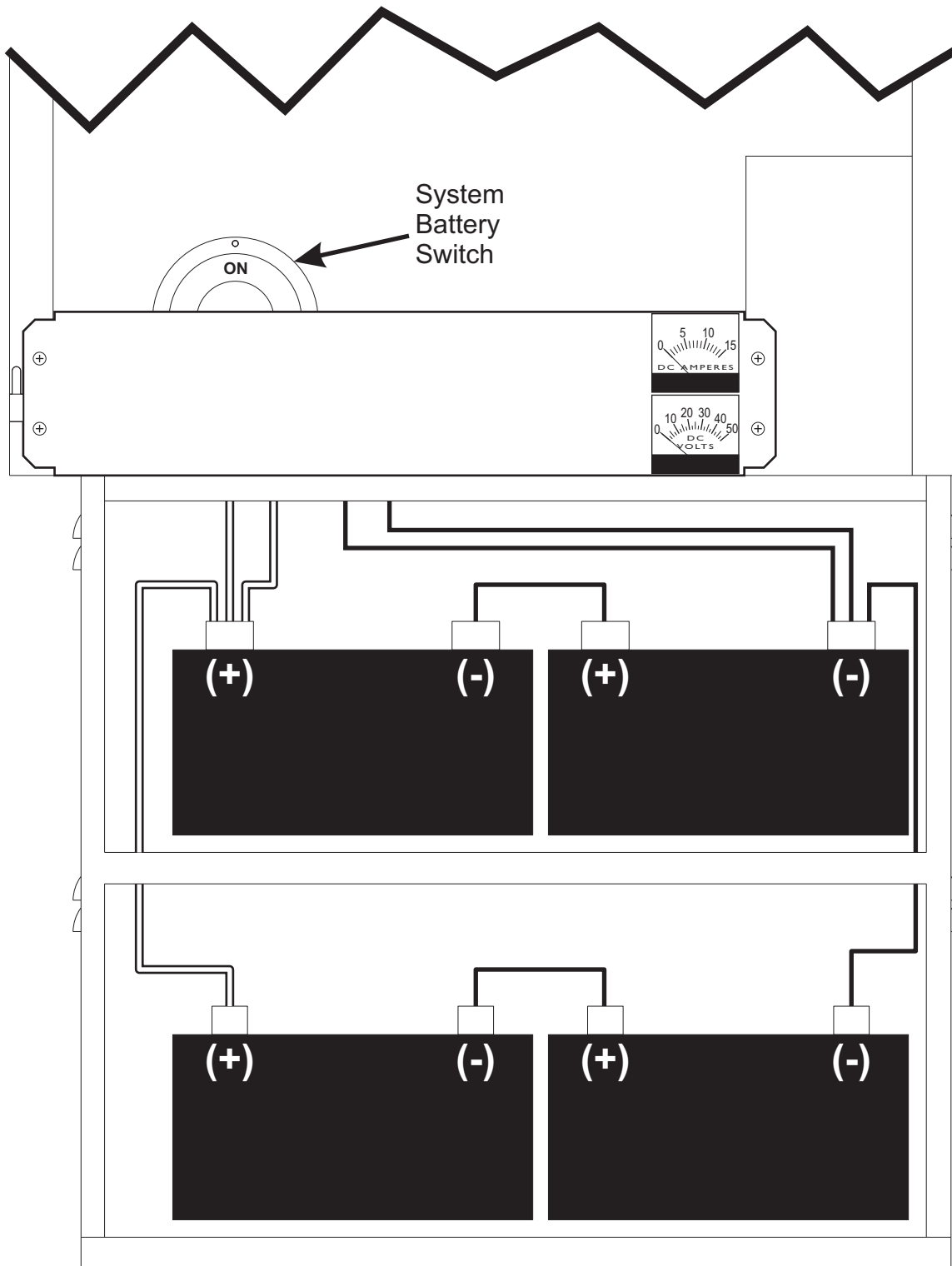

Fig. 16: Battery Connections (Type III Cabinet)



d) Landline (optional)

As an option, the WPS-2900 may be remotely controlled by either landline or RF link. Both methods communicate via DTMF protocol. Remote control may be one-way or two-way. The one-way option simply controls the WPS-2900, while the two-way option controls the WPS-2900 and reports WPS-2900 status back to a central control point.

Fig. 17: Landline Wiring

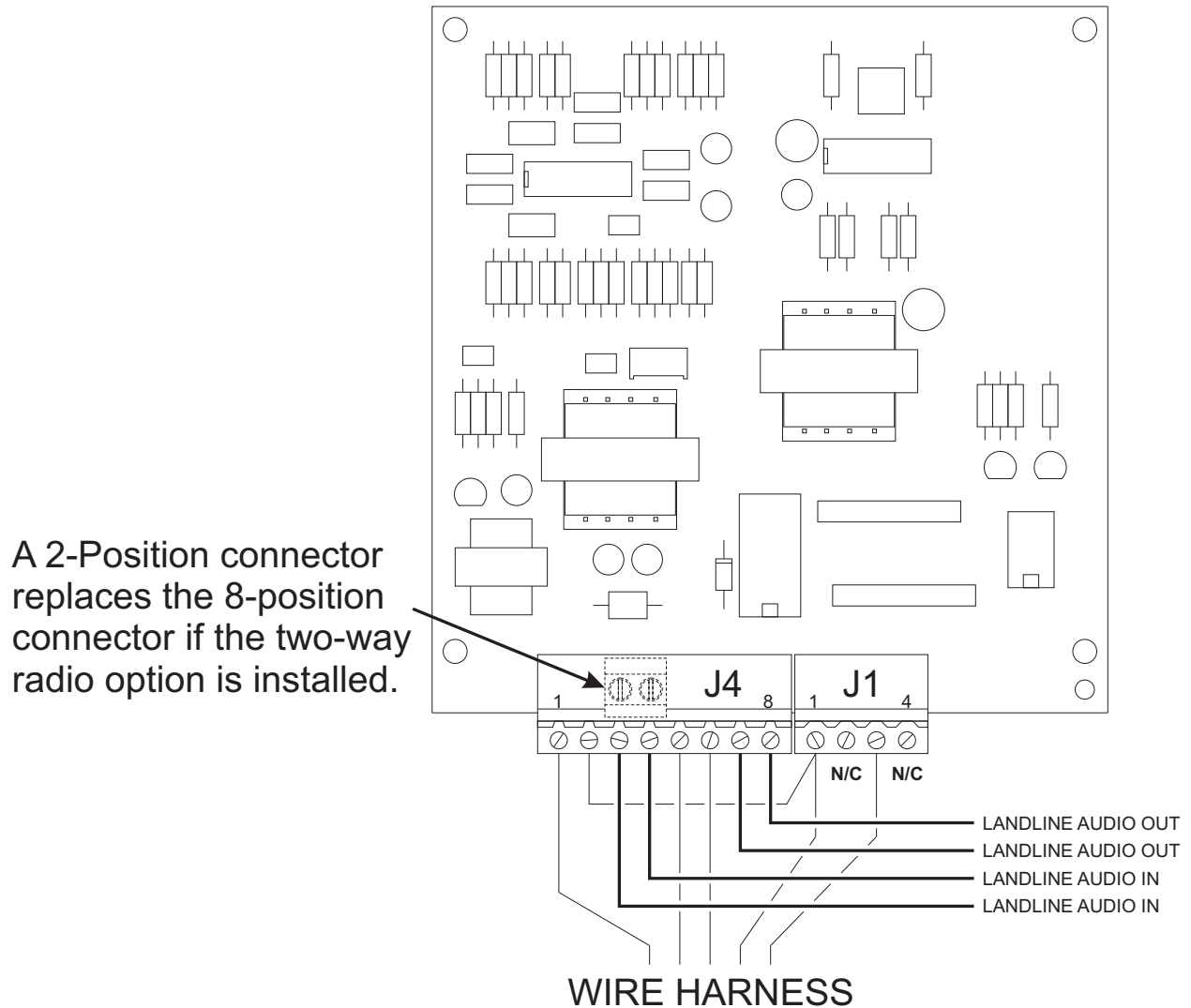

e) Auxiliary Control/Status (optional)

The WPS-2900 may be equipped with an optional module that allows the user to remotely control siren functions and to remotely collect siren status information. The following Whelen commands are supported:

- Cancel (or Clear)
- Wail
- Attack
- Alert
- Public Address
- Air Horn
- Hi/Low
- Whoop
- Noon Test
- Digital Voice Messages (1 - 16)
- Silent Test
- Silent Test Clear
- North*
- East*
- South*
- West*
- Clockwise*
- Counter-Clockwise*
- Strobe On
- Strobe Off

* = Not available for the WPS-2900

The following status bits are supported with Normally Open relay closures:

AC	AC Voltage is present
DC	DC Voltage level is good
Partial	At least one amplifier is active
Full	All amplifiers and drivers are active
Rotor	Rotor Active
Intrusion	Intrusion active

In addition to commands and status functions, the Auxiliary Control/Status Option has transformer coupled circuits for accepting audio. One circuit is active in conjunction with the Public Address command, while the other circuit is used for local audio, such as a local microphone or paging system. The local audio must have a “Push To Talk” contact closure for operation. In either case the audio is broadcast over the system.

To activate one of the supported commands, simply make a closure between the desired command input and ground. Typically, a relay is used to make a remote connection. An open collector device may be used, as long as it meets the electrical specifications of this document.

When an input is activated by a momentary closure, the siren function will run for the pre programmed time or until another command is activated. For example, the Cancel command will override a warning tone and silence the siren. Note that if a closure is maintained, it can not be overridden.

The local audio path operates a little differently than the other commands. The “Push To Talk” closure must be maintained for the duration of the command, however, the activation will automatically turn off if held active for more than 8 minutes.

The input cables may be up to 4,000 feet away, based on at least 26 AWG cable. Any audio cable must be shielded, twisted-pair and grounded at the audio source.

<u>Terminal Block 1</u> <u>Contact Number</u>	<u>Input Function</u>
1.	Ground
2.	Cancel Command Input
3.	Wail Command Input
4.	Attack Command Input
5.	Alert Command Input
6.	Public Address Command Input
7.	Ground
8.	Air Horn Command Input
9.	Hi/Low Command Input
10.	Whoop Command Input
11.	Noon Test Input
12.	Silent Test Command Input
13.	Ground
14.	Silent Test Clear Input
15.	Message 1 Input
16.	Message 2 Input
17.	Message 3 Input
18.	Message 4 Input
19.	Ground
20.	Message 5 Input
21.	Message 6 Input
22.	Message 7 Input
23.	Message 8 Input

<u>Terminal Block 1</u> <u>Contact Number</u>	<u>Input Function</u>
24.	Message 9 Input
25.	Ground
26.	Message 10 Input
27.	Message 11 Input
28.	Message 12 Input
29.	Message 13 Input
30.	Message 14 Input
31.	Ground
32.	Message 15 Input
33.	Message 16 Input
34.	North Command Input
35.	East Command Input
36.	South Command Input
37.	Ground
38.	West Command Input
39.	Clockwise Command Input
40.	CCW Command Input
41.	Strobe On Command Input
42.	Strobe Off Command Input
43.	Ground
44.	Remote Audio Input
45.	Remote Audio Input

<u>Terminal Block 2</u> <u>Contact Number</u>	<u>Function</u>
1.	AC Status N.O.
2.	AC Status N.O.
3.	DC Status N.O.
4.	DC Status N.O.
5.	Partial Status N.O.
6.	Partial Status N.O.

<u>Terminal Block 2</u> <u>Contact Number</u>	<u>Function</u>
7.	Full Status N.O.
8.	Full Status N.O.
9.	Rotor Status N.O.
10.	Rotor Status N.O.
11.	Intrusion Switch N.O.
12.	Intrusion Switch N.O.

<u>Terminal Block 3</u> <u>Contact Number</u>	<u>Function</u>
1.	Push To Talk Input
2.	Push To Talk Ground

<u>Terminal Block 3</u> <u>Contact Number</u>	<u>Function</u>
3.	Local Audio Input
4.	Local Audio Input

Electrical Input Specifications

Minimum Closure Time 250ms
Low Level Current (min.): 35 mA
High Level Voltage (max): 32VDC
Audio Input Level: -17 to +10 dB

Electrical Output Specifications

Minimum Voltage Rating 24VDC
Current Rating: 250 mA

One (1) wiring harness is supplied to connect the ESC2020 Controller to the Auxiliary Control/Status (AUXCS) Option Board.

A 16-position connector, J1, as well as a 3-position connector, J2, are mounted onto the AUXCS circuit board. J1 controls the status and control functions available in the AUXCS board. J2 controls the PA/audio functions. The single harness comes out of the ESC2020 Controller with an 18-position connector, J11. All of the available functions of the AUXCS board are addressed through this one single harness.

Fig. 18: Auxiliary Control/Status Board Wiring

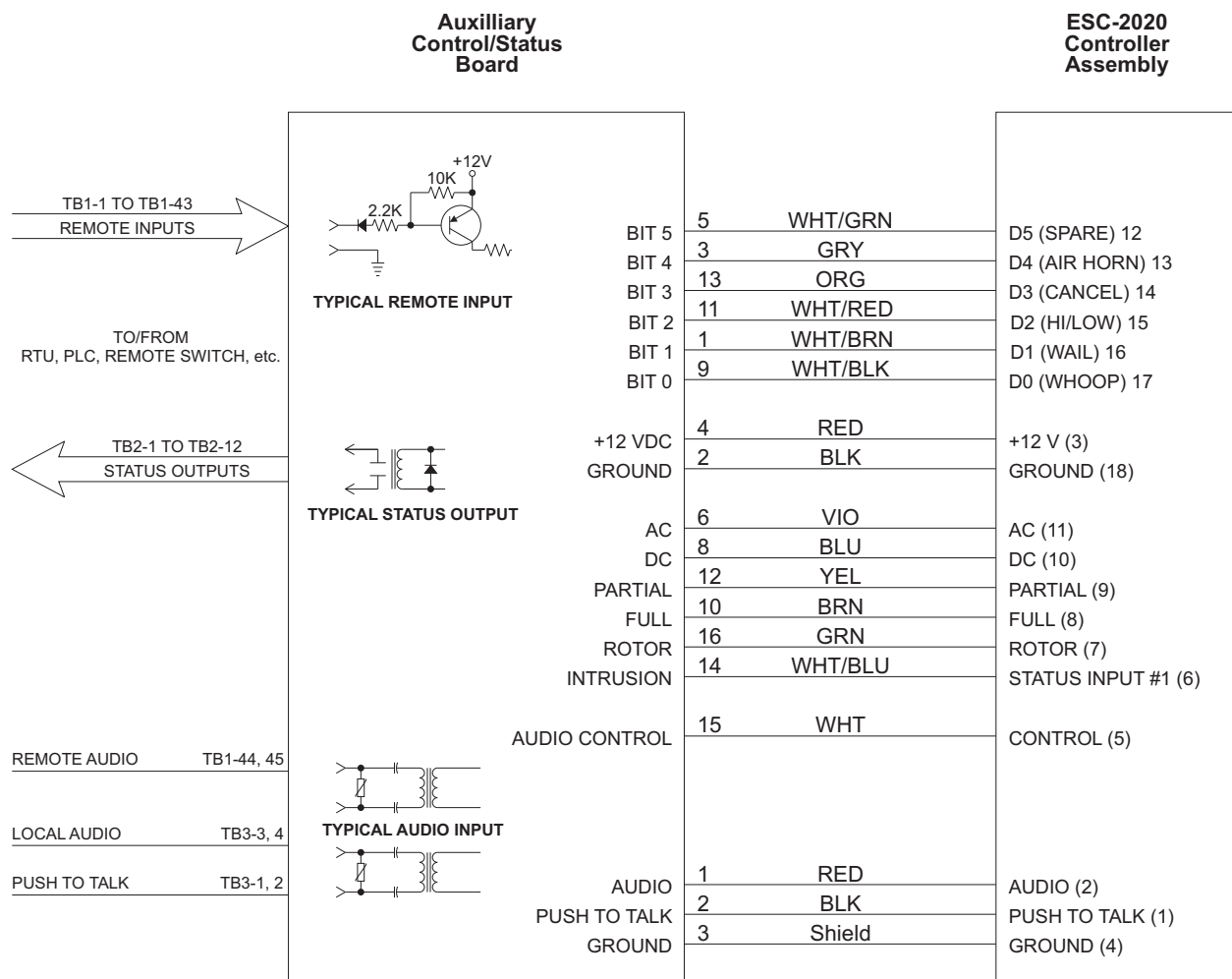

There are three potentiometers for audio level adjustments on the AUXCS board. Refer to the diagram below for the location of these potentiometers.

The potentiometers are factory set for typical signal levels, however, some adjustment may be necessary depending on the actual audio source in the field.

The upper most potentiometer has been calibrated at the factory for a minimum clipping level. **THIS POTENTIOMETER SHOULD NOT BE ADJUSTED!** The Receive Audio and/or the Local Audio potentiometers are adjusted until the clipping indicator LED just starts to flicker on. The Local Audio potentiometer is the one toward the rear of the cabinet, while the Receive Audio potentiometer is the one toward the front of the cabinet.

NOTE: The front panel MIC VOLUME control should be set full volume (clockwise) if the AUXCS option is being used.

Fig. 19: Auxiliary Control/Status Potentiometer Locations

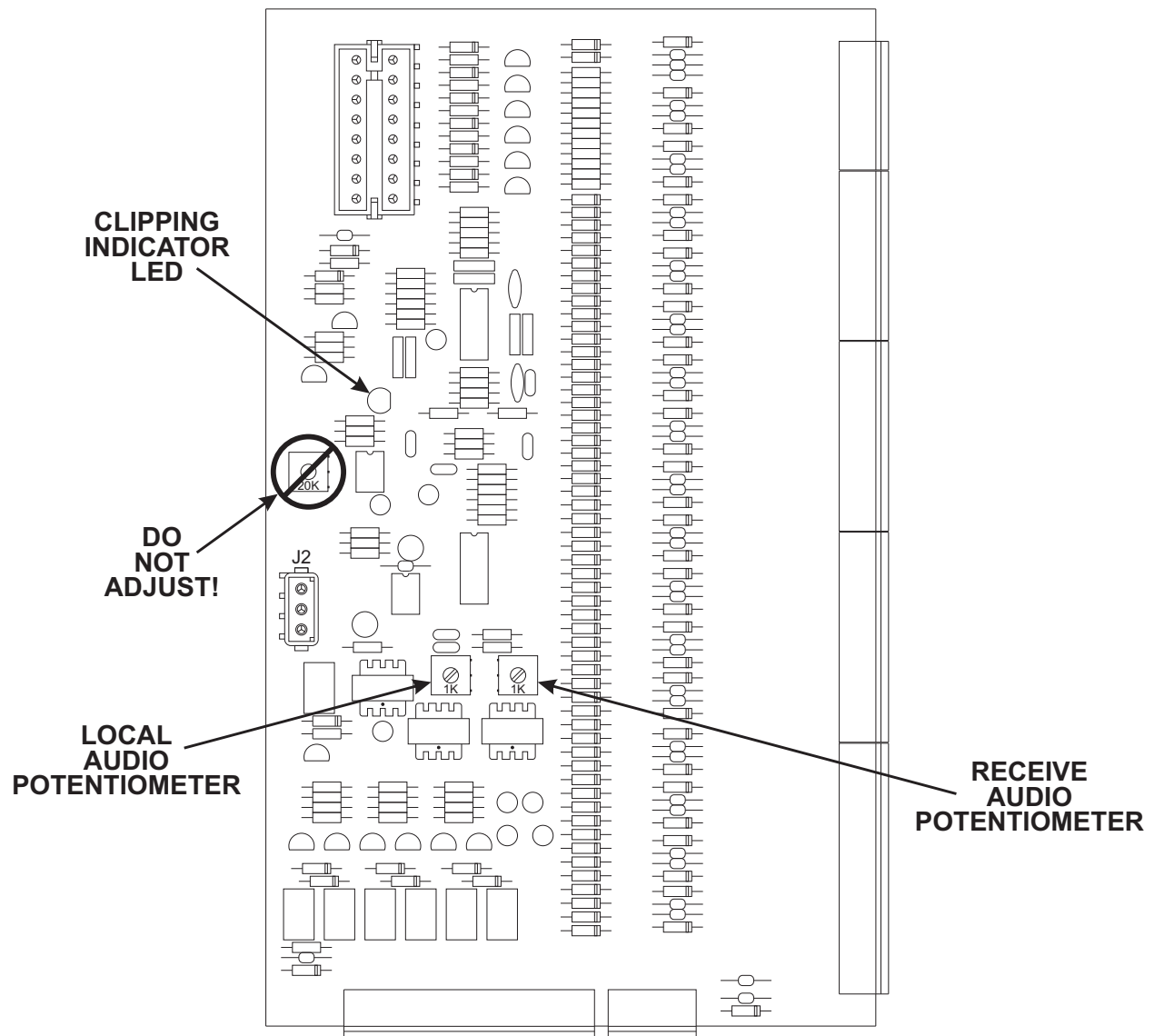

f) Paging Interface (optional)

The WPS-2900 may be equipped with an optional module that allows the user to broadcast siren tones, digital voice messages or public address through existing in-plant public address systems.

The audio output of the Paging Interface Module is a 600 ohm, transformer coupled signal. This output interfaces with most industry standard paging systems. A level adjustment potentiometer allows the user to set the siren output to a desirable level, through the public address system.

The Paging Interface Module also has an output relay that makes a 1 amp rated, contact closure whenever the siren audio is active. This is typically used to perform the in-plant PA microphone “Push-To-Talk” function.

<u>Customer Interface</u>	<u>Output Function</u>	<u>Connector J2</u> <u>(factory wired)</u>	<u>Input Function</u>
J3-1	Audio Out	1	Bias Input
J3-2	Audio Out	2	PA Relay
		3	Audio In
J1-1	N.O., 1 Amp Contact	4	Audio In
J1-2	N.O., 1 Amp Contact	5	+12VDC
		6	Ground
		7	not used

Fig. 20: Paging Interface Board

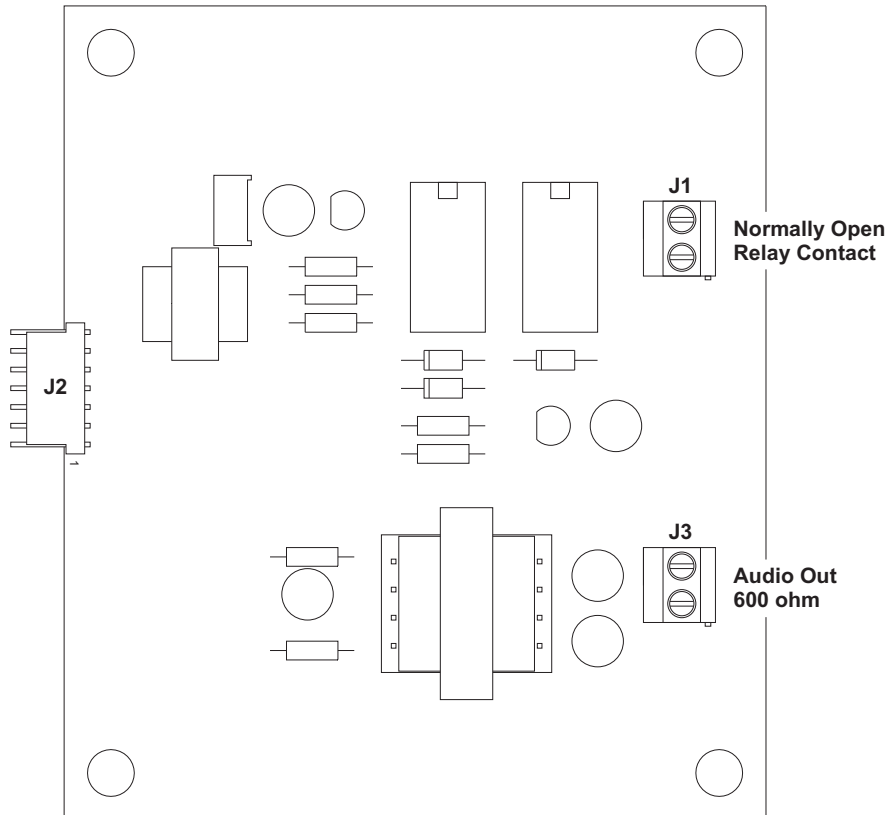

g) Strobe Control Options STCTRL & SCWPS

The WPS-2900 may be equipped with an optional, highly visible external strobe light which upon activation provides a visual indication during siren operation.

The STCTRL includes the strobe control board, cable, hardware for mounting the board to the inside of the cabinet and the mating connector. This board comes complete with all the necessary components to be able to control a strobe using power from inside the cabinet.

The SCWPS provides the same components, strobe control board, cable, mounting hardware and mating connector, but additionally includes a mounting plate (including all necessary hardware) to mount an ISB24 strobe to the top of the siren. The appropriate length of strobe power cable (including connectors) to reach from the top of the siren to the cabinet is also included. Please note that the ISB24 is NOT included and must be purchased separately.

The strobe control board has two functions. The first is to switch 24VDC. The second is to provide a contact closure with a 10A relay. These functions allow for the use of strobe(s) in combination with the siren to activate and operate at the same time.

Fig. 21: Strobe Control Board

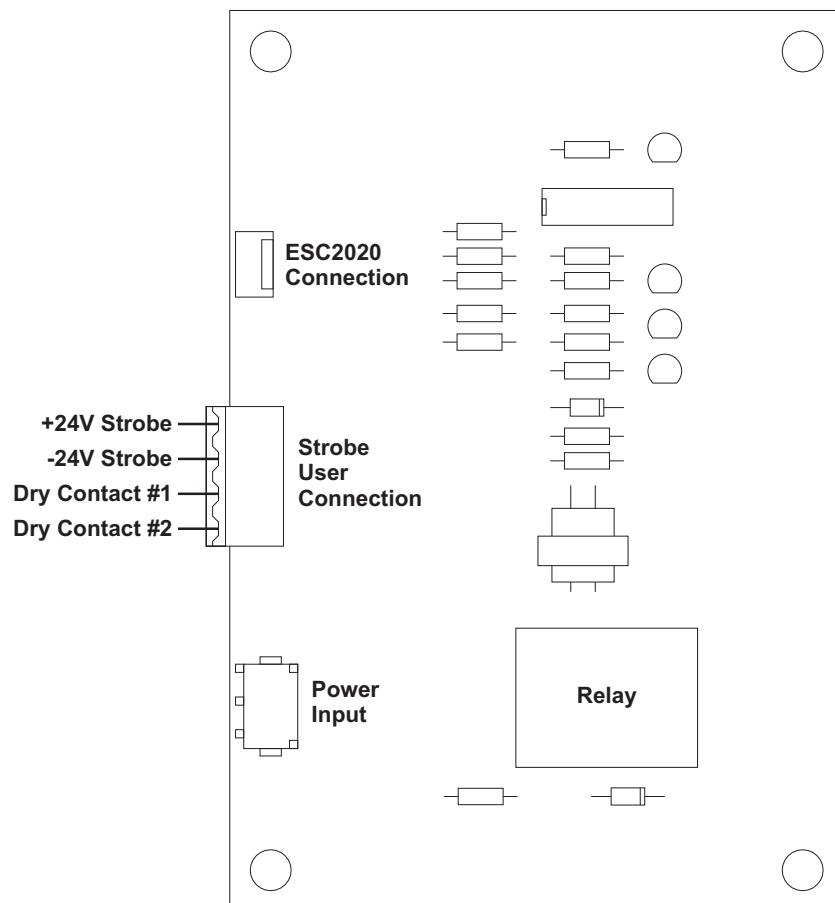

h) Auxiliary Input Board

The WPS-2900 may be equipped with an optional module that can activate siren functions via an external auxiliary input contact closure. For external controls, the “closure” must be at least 1/2 second in duration. The “closure” must be made to ground. A ground contact is supplied at the terminal strip for this purpose. The following Whelen Commands are supported:

- **Cancel (or Clear)**
- **Wait**
- **Attack**
- **Alert**
- **Airhorn**
- **Hi/Low**
- **Whoop**
- **Noon Test**
- **Silent Test**
- **Digital Voice Messages 1 - 4**

Fig. 22: Auxiliary Input Board

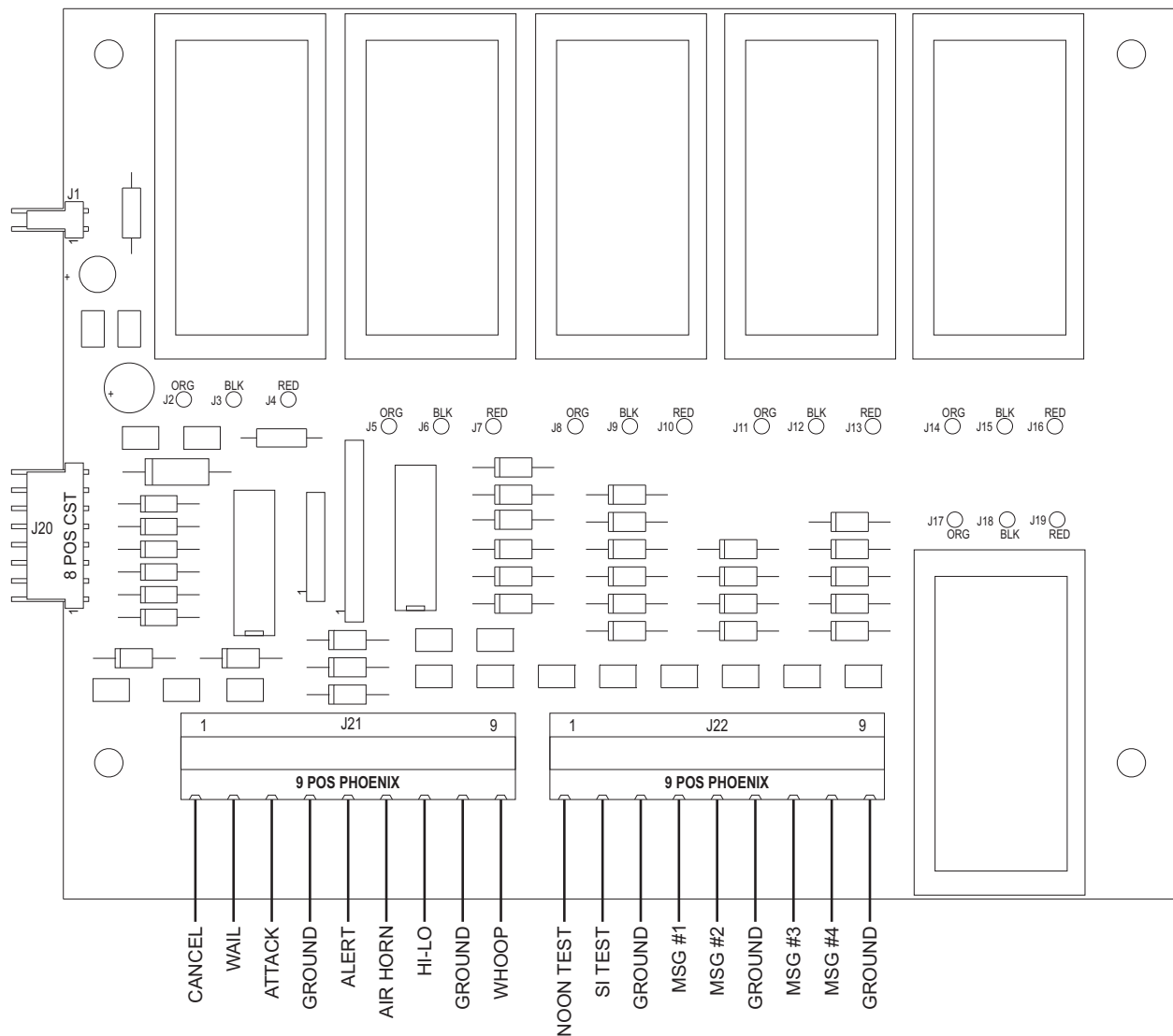

To activate one of the supported commands, simply make a momentary dry closure between the desired command input and ground. Typically, a relay is used to make a remote connection. When an input is activated by a momentary closure, the siren function will run for the pre-programmed time or until another command is activated. For example, the Cancel (or Clear) command will override a warning tone and silence the siren. Note that if a closure is maintained, it can not be overridden.

One harness, one board and 4 mounting screws are supplied with the AUXIN option for connecting to the ESC-2020 Controller. The supplied harness connects from the ESC-2020 controller into an 8 position connector, J20, on the AUXIN board.

NOTE: AUXIN will not work with older ESC-864 controller based sirens.

Auxiliary Input Board Pin-outs

<u>Terminal Block J22 Contact Number</u>	<u>Input Function</u>
1.	Noon Test
2.	Silent Test
3.	Ground
4.	Digital Voice Msg. #1
5.	Digital Voice Msg. #2

<u>Terminal Block J22 Contact Number</u>	<u>Input Function</u>
6.	Ground
7.	Digital Voice Msg. #3
8.	Digital Voice Msg. #4
9.	Ground

<u>Terminal Block J21 Contact Number</u>	<u>Input Function</u>
1.	Cancel (or Clear)
2.	Wail
3.	Attack
4.	Ground
5.	Alert

<u>Terminal Block J21 Contact Number</u>	<u>Input Function</u>
6.	Air Horn
7.	Hi/Low
8.	Ground
9.	Whoop

i) Two-tone Decoder Board

The WPS-2900 may be equipped with an optional module for decoding two-tone frequencies. The two-tone decoder may be equipped with up to six (6) decode modules. The appropriate decode module is factory wired to the appropriate command, provided that information has been supplied to the factory.

The tables on the following page list the timing sequences and tones that are supported by the two-tone decoder. Up to six (6) modules may be used on one decoder board. Any one timing sequence may be used for each module, with the first and second tones always being from the same tone table.

Section V: System Test...

After the installation of the WPS-2900 station has been completed, a basic system check is recommended to confirm that the system is functioning properly. Before initiating these tests, locate the system LED's on the main control board mounted to the cabinet door (see "Fig. 23: System LED Diagnostic Indicators" on page 43).

NOTE: The KEYPAD ARM button enables local station operation via keypad. Once pressed, the keypad remains active until either a) another keypad button is pressed, or b) 60 seconds have elapsed, whichever comes first. The KEYPAD ARM button must be pressed each time a keypad button is to be pressed. Note that the CANCEL button is always enabled and does not require Keypad Arm to be pressed.

1. Confirm that the ACTIVE light on the control board is flashing at a rate of a 1/2 second on and a 1/2 second off.
2. Press KEYPAD ARM, then the SI TEST® button on the siren front panel and check to make sure that all the siren amplifier diagnostic LED's illuminate for 5 seconds. These LED's are located on the front of the cabinet door.
3. After the amplifier LED's turn off, check to see if the AC, DC, PARTIAL and FULL LED's are on.

If one of your amplifier lights did not illuminate during this test then refer to the procedure below to troubleshoot the problem.

This procedure may be used when the Partial or Full LED's indicate a failure.

NOTE: In order for a "Full" indication to be valid, the "Partial" LED must also be on.

1. Press KEYPAD ARM, then the SI TEST® button located on the front panel of the electronic cabinet. Each amplifier has a red LED diagnostic indicator that is visible on the front panel (see "Fig. 24: Electronic Cabinet Front Panel (Type II)." on page 44).
2. A SI TEST® will cause each amplifier's diagnostic indicator to turn on. If one or more do not turn on, proceed to step 3. If all indicators turn on, the siren amplifiers are functioning properly.
3. Open the front panel and remove the speaker driver from the amplifier that did not light and install it onto an amplifier that did light. For example: If amplifier 1 did not light but amplifier 2 did, install speaker 1 on amplifier 2 and speaker 2 on amplifier 1. This will indicate if the failure was with the speaker or the amplifier. For more information on troubleshooting the system, refer to the advanced trouble shooting manual.

Fig. 23: System LED Diagnostic Indicators

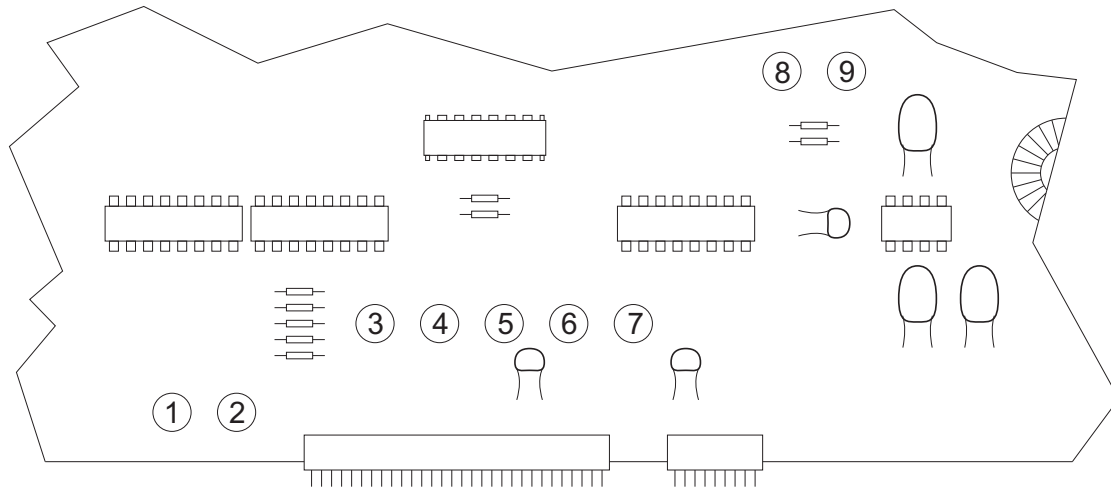

- | | |
|---|---|
| <p>① Fault (RED) - Normally off. When a problem has been detected, this LED will be on.</p> <p>② Active - This LED normally flashes at a rate of once every half seconds. When a problem has been detected, this LED will stop flashing or be off. Also indicates receipt of DTMF data by flashing at a faster rate for about 1 second.</p> <p>③ Rotator - This LED is not used with the WPS-2800 system.</p> <p>④ Full - Normally on. If a siren amplifier does not operate properly during a tone activation or SI TEST®, this LED will be off.</p> <p>⑤ Partial - Normally on. If all siren amplifiers do not operate properly during a tone activation or SI TEST®, this LED will be off. If at least one amplifier operates properly, it will remain on.</p> | <p>⑥ DC - Normally on. If no DC voltage was detected during a siren tone or SI TEST®, this LED will be off.</p> <p>⑦ AC - Normally on. If no DC voltage was detected during a siren tone or SI TEST®, this LED will be off.</p> <p>⑧ Squelch - Normally off. This LED will light when the station is receiving a radio broadcast. If equipped with the optional receive tone/squelch tone, the LED will only light when the receive frequency and sub-audible tone squelch frequency tone is detected.</p> <p>⑨ PTT - Normally off. This LED will light when the station transmitter is active.</p> |
|---|---|

NOTE: In some instances, optional circuit boards may be located directly above these LED's.

Fig. 24: Electronic Cabinet Front Panel (Type II).

Siren Amplifier
Diagnostic LED's
(7 cell system shown
for reference)

