

WHELEN[®]

ENGINEERING COMPANY INC.

51 Winthrop Road
Chester, Connecticut 06412-0684
Phone: (860) 526-9504
Internet: www.whelen.com
Sales e-mail: autosale@whelen.com
Customer Service e-mail: custserv@whelen.com

Installation Guide:
Model(s) SA340STS, SA340TS
Siren Speaker

DANGER! Sirens produce extremely loud emergency warning tones! Exposure to these tones without proper and adequate hearing protection, could cause ear damage and/or hearing loss! The Occupational Safety & Health Administration (www.osha.gov) provides information necessary to determine safe exposure times in Occupational Noise Exposure Section 1910.95. Until you have determined the safe exposure times for your specific application, operators and anyone else in the immediate vicinity should be required to wear an approved hearing protection device. Failure to follow this recommendation could cause hearing loss!

Warnings to Installers

Whelen's emergency vehicle warning devices must be properly mounted and wired in order to be effective and safe. Read and follow all of Whelen's written instructions when installing or using this device. Emergency vehicles are often operated under high speed stressful conditions which must be accounted for when installing all emergency warning devices. Controls should be placed within convenient reach of the operator so that they can operate the system without taking their eyes off the roadway. Emergency warning devices can require high electrical voltages and/or currents. Properly protect and use caution around live electrical connections. Grounding or shorting of electrical connections can cause high current arcing, which can cause personal injury and/or vehicle damage, including fire. Many electronic devices used in emergency vehicles can create or be affected by electromagnetic interference. Therefore, after installation of any electronic device it is necessary to test all electronic equipment simultaneously to insure that they operate free of interference from other components within the vehicle. Never power emergency warning equipment from the same circuit or share the same grounding circuit with radio communication equipment. All devices should be mounted in accordance with the manufacturer's instructions and securely fastened to vehicle elements of sufficient strength to withstand the forces applied to the device. Driver and/or passenger air bags (SRS) will affect the way equipment should be mounted. This device should be mounted by permanent installation and within the zones specified by the vehicle manufacturer, if any. Any device mounted in the deployment area of an air bag will damage or reduce the effectiveness of the air bag and may damage or dislodge the device. Installer must be sure that this device, its mounting hardware and electrical supply wiring does not interfere with the air bag or the SRS wiring or sensors. Mounting the unit inside the vehicle by a method other than permanent installation is not recommended as unit may become dislodged during swerving; sudden braking or collision. Failure to follow instructions can result in personal injury. Whelen assumes no liability for any loss resulting from the use of this warning device. PROPER INSTALLATION COMBINED WITH OPERATOR TRAINING IN THE PROPER USE OF EMERGENCY WARNING DEVICES IS ESSENTIAL TO INSURE THE SAFETY OF EMERGENCY PERSONNEL AND THE PUBLIC.

Warnings to Users

Whelen's emergency vehicle warning devices are intended to alert other operators and pedestrians to the presence and operation of emergency vehicles and personnel. However, the use of this or any other Whelen emergency warning device does not guarantee that you will have the right-of-way or that other drivers and pedestrians will properly heed an emergency warning signal. Never assume you have the right-of-way. It is your responsibility to proceed safely before entering an intersection, driving against traffic, responding at a high rate of speed, or walking on or around traffic lanes. Emergency vehicle warning devices should be tested on a daily basis to ensure that they operate properly. When in actual use, the operator must ensure that both visual and audible warnings are not blocked by vehicle components (i.e.: open trunks or compartment doors), people, vehicles, or other obstructions. It is the user's responsibility to understand and obey all laws regarding emergency warning devices. The user should be familiar with all applicable laws and regulations prior to the use of any emergency vehicle warning device. Whelen's audible warning devices are designed to project sound in a forward direction away from the vehicle occupants. However, because sustained periodic exposure to loud sounds can cause hearing loss, all audible warning devices should be installed and operated in accordance with the standards established by the National Fire Protection Association.

Safety First

This document provides all the necessary information to allow your Whelen product to be properly and safely installed. Before beginning the installation and/or operation of your new product, the installation technician and operator must read this manual completely. Important information is contained herein that could prevent serious injury or damage.

- Proper installation of this product requires the installer to have a good understanding of automotive electronics, systems and procedures.
- Whelen Engineering requires the use of waterproof butt splices and/or connectors if that connector could be exposed to moisture.
- Any holes, either created or utilized by this product, should be made both air- and watertight using a sealant recommended by your vehicle manufacturer.
- Failure to use specified installation parts and/or hardware will void the product warranty.
- If mounting this product requires drilling holes, the installer MUST be sure that no vehicle components or other vital parts could be damaged by the drilling process. Check both sides of the mounting surface before drilling begins. Also de-burr the holes and remove any metal shards or remnants. Install grommets into all wire passage holes.
- If this manual states that this product may be mounted with suction cups, magnets, tape or Velcro®, clean the mounting surface with a 50/50 mix of isopropyl alcohol and water and dry thoroughly.
- Do not install this product or route any wires in the deployment area of your air bag. Equipment mounted or located in the air bag deployment area will damage or reduce the effectiveness of the air bag, or become a projectile that could cause serious personal injury or death. Refer to your vehicle owner's manual for the air bag deployment area. The User/Installer assumes full responsibility to determine proper mounting location, based on providing ultimate safety to all passengers inside the vehicle.
- For this product to operate at optimum efficiency, a good electrical connection to chassis ground must be made. The recommended procedure requires the product ground wire to be connected directly to the NEGATIVE (-) battery post (this does not include products that use cigar power cords).
- If this product uses a remote device for activation or control, make sure that this device is located in an area that allows both the vehicle and the device to be operated safely in any driving condition.
- It is recommended that these instructions be stored in a safe place and referred to when performing maintenance and/or reinstallation of this product.
- FAILURE TO FOLLOW THESE SAFETY PRECAUTIONS AND INSTRUCTIONS COULD RESULT IN DAMAGE TO THE PRODUCT OR VEHICLE AND/OR SERIOUS INJURY TO YOU AND YOUR PASSENGERS!

**ACTIVATION OF THIS
SIREN MAY DAMAGE
UNPROTECTED EARS!**



CAUTION

Loud siren noise can cause hearing damage and/or loss. Refer to OSHA Section 1910.95 prior to putting ANY siren into service!

Selecting a Mounting Location: The mounting location should not only be as flat as possible to allow the speaker tone to be projected in a direction parallel with the road.

IMPORTANT! It is the responsibility of the installation technician to make sure that the installation and operation of this product will not interfere with or compromise the operation or efficiency of any vehicle equipment!

Caution: Permanent mounting of this product will require drilling. It is absolutely necessary to make sure that no other vehicle components could be damaged by this process. Check both sides of the mounting surface before starting. If damage is likely, select a different mounting location.

Fig. 2

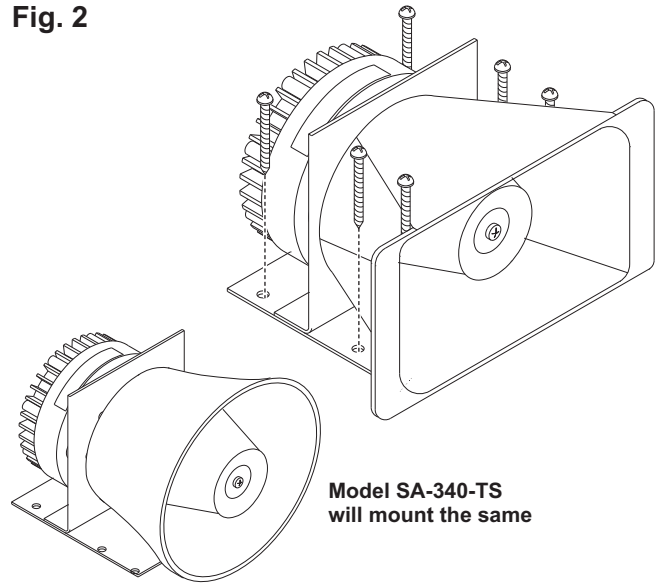
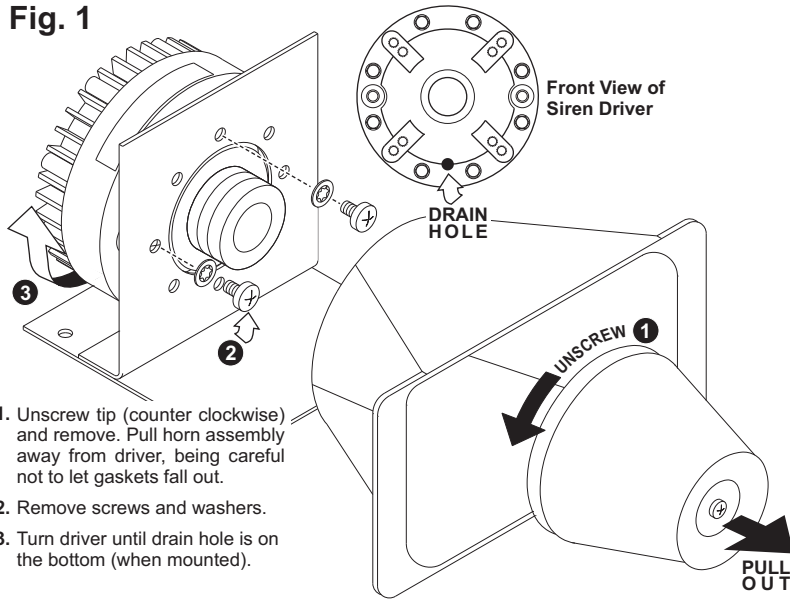

Fig. 1



1. Unscrew tip (counter clockwise) and remove. Pull horn assembly away from driver, being careful not to let gaskets fall out.
2. Remove screws and washers.
3. Turn driver until drain hole is on the bottom (when mounted).

Installation:

1. Position the bracket onto the desired mounting area and, using the bracket as a template, mark off the 6 mounting holes. **IMPORTANT!** Make sure that the drainage hole is located on the bottom of the siren after it is mounted. If the drainage hole will not be located correctly with the bracket mounted, loosen the driver and turn it so that the driver properly oriented (see Fig. 1).
2. Drill an appropriately sized hole into the mounting surface for each mounting screw location marked off in Step 1 (Fig. 2).
3. Secure the bracket onto the mounting surface with the customer supplied mounting hardware.
4. Extend the WHITE (Positive) and BLACK (Negative) speaker wires to your amplifier and connect as shown in the amplifier's instructions.

IMPORTANT! Before returning the vehicle to active service, confirm the proper operation of this product, as well as all vehicle components/equipment.

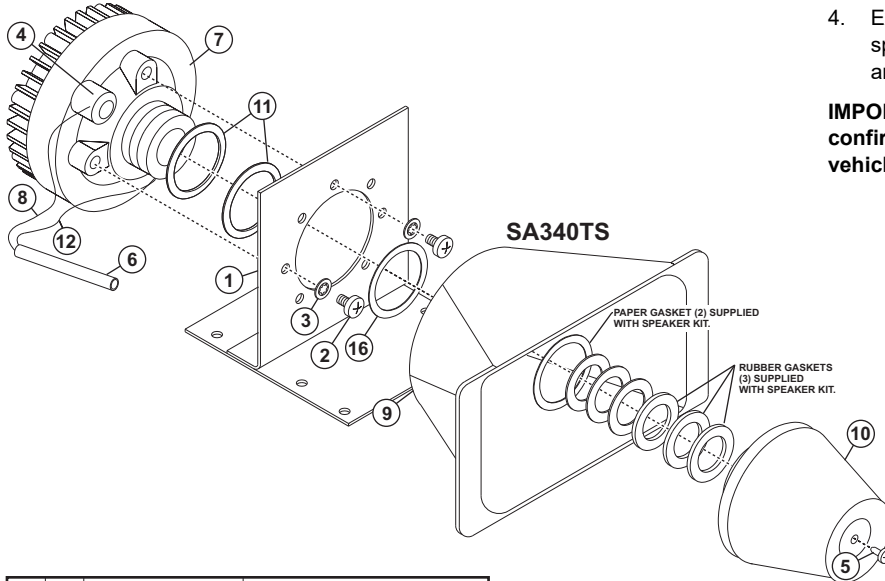

QTY	ITEM	PART NUMBER	DESCRIPTION
*		01-0881013-00C	MODEL SA-340-TS F/A
1	1	07-280414-010C	BRACKET-TWINSONIC FOR SD-500
4	2	14-130216-060C	1/4-20 X 3/8" PHMS
4	3	16-1321560-02C	1/4" INTERNAL L'WASHER
2	4	26-0716563-04	3/16" X 1" SHRINK TUBING
REF	5	15-081416-080	SCREW-#8 X 1/2" LG. PPHSMS
1	6	26-0610158-00C	PVC TUBING-BLACK 6" LG
1	7	43-0263146-00	DRIVER SANMING 100W SD-210R
1	8	67-1361699150	1/C 16 GA. WIRE WHT 15' LG. W/FSTN
1	9	72-3180579-00C	FLARE-TWINSONIC
1	10	72-4010291-00	TIP SA510-M1
2	11	38-0220047-00	METAL GASKET
1	12	67-1361600150	1/C 16 GA. WIRE BLK. 15" LG. W/FSTN

QTY	ITEM	PART NUMBER	DESCRIPTION
*		01-0861413-00	SA-340-TS
1	1	15-081416-080	8 x 1/2" PPHSMS
1	2	72-4010291-00	TIP-SA510-M1
1	3	72-1040522-06	SPEAKER BELL SA-974
4	4	38-0220047-00	METAL GASKET
1	5	43-0263146-00	DRIVER SANMING 100W SD-210R
1	6	07-280414-010	BRACKET
4	7	16-1321560-02	1/4" INT. TOOTH WASHER
4	8	14-130216-060	1/4"-20 x 3/8" PPHMS
2	9	26-0716563-04	3/16" X 1" SHRINK TUBING
1	10	67-1361600150	16 GA BLK 15" (1) FASTON
1	11	26-0610158-00	PVC TUBE 6" BLK
1	12	67-1361699150	16 GA 15" (1) FASTON

